

HSF

NOTES:

Current Rating: 2.0AMP
 Contact Resistance: 20mΩ Max
 Withstand Voltage: 500V AC
 Insulation Resistance: 1000MΩ Min
 Operation Temperature: -40℃ to +105℃

Contact Material: Phosphor Bronze
 Contact plating: Au Or Sn over Ni
 Insulator Material: LCP+30%G.F UL94V-0

Ordering Information

2263 - 2 XX R XX DYN T X

No. of Pins per ROW: 02-40PIN

Insulator: D=LCP

Packing: T=Tube

Contact Plating:
 G0=Gold Flash
 G3=10μ"Gold
 G4=15μ"Gold
 G5=30μ"Gold
 S0=Gold Flash/Tin
 S3=10μ"Gold/Tin
 S4=15μ"Gold/Tin
 S5=30μ"Gold/Tin
 SN=Tin
 SM=Matte Tin

Type
 1: A=2.9 W/O Bump
 4: A=2.9 W/T Bump

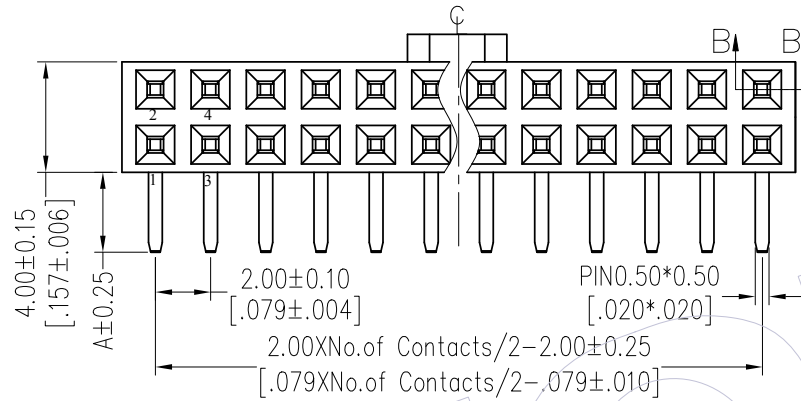

Recommended P.C.B Layout (Top Side)
 (PCB BOARD TOLERANCE ±0.05)

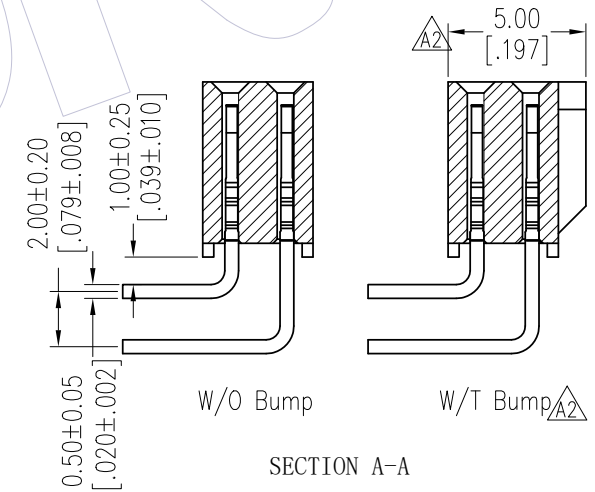
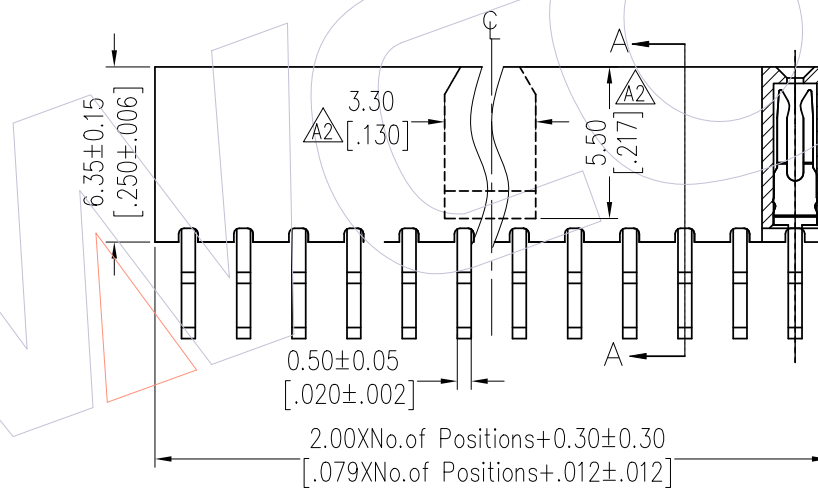
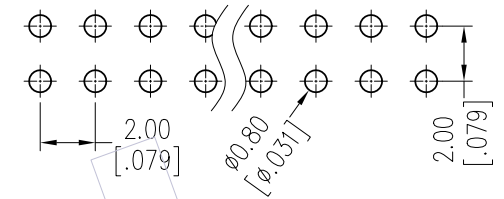

Item	Pitch	DIM A	Mating
Standard	2.00	2.90	1215/1220
Alternate			

REV	DATE	MODIFICATION DESCRIPTION	CHANGE	OPERATION	DRAW	DATE	SCALE	FIT	PART NO.
A2	2021/06/07	Add W/T BUMP SPEC&P/N	XSR	x.x ±0.40	XSR	2021/06/07	UNIT	mm	2263-2XXRXXDYNTX
A1	2013/03/15	Modify drawing	-----	x.xx ±0.25	CHECK	DATE	SIZE	A4	TITLE: 2.00mm Female Header DUAL ROW 90°DIP H=6.35
A0	2012/12/07	NEW	-----	x.xxx ±0.15	APPROVE	DATE	SHEET	1/1	Customer NO.
				Angle ± 3°			PROJ.		
				DIM TOL					

WCON
 Http: www.wcon.com

WCON-Dongguan
 Tel: +86 769 85358920
 Fax: +86 769 85358915
 E-mail: sales@wcon.com

WCON-Kunshan
 Tel: +86 512 57468408
 Fax: +86 512 57468468
 E-mail: salesks@wcon.com