

# HSF

**NOTES:**

Rated Current:1.5AMP at 250V AC  
 Rated Voltage:30V  
 Contact Resistance:30mΩ max  
 Withstand Voltage:500V AC  
 Insulation Resistance:1000MΩ min  
 Operation Temperature:-20°C to +60°C

Contact Material:Brass T=0.25  
 Contact Plating:Au and SM Over Ni  
 Shell Material:Brass T=0.30  
 Shell Plating:Sn over Ni  
 Insulator Material:PBT UL94V-0



Insertion Force:35 Newtons Maximum  
 Extraction Force:10 Newtons Minimum

## Ordering Information

6110-04 A F S D XX B N A 1

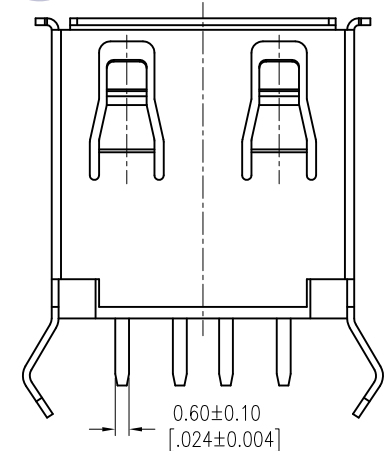
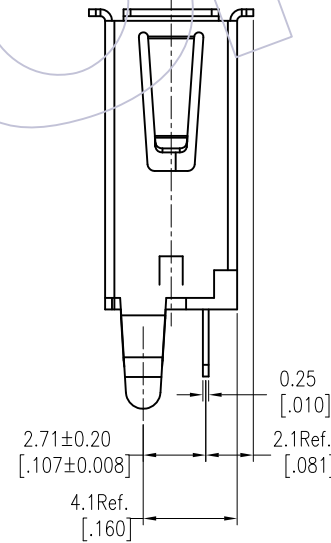
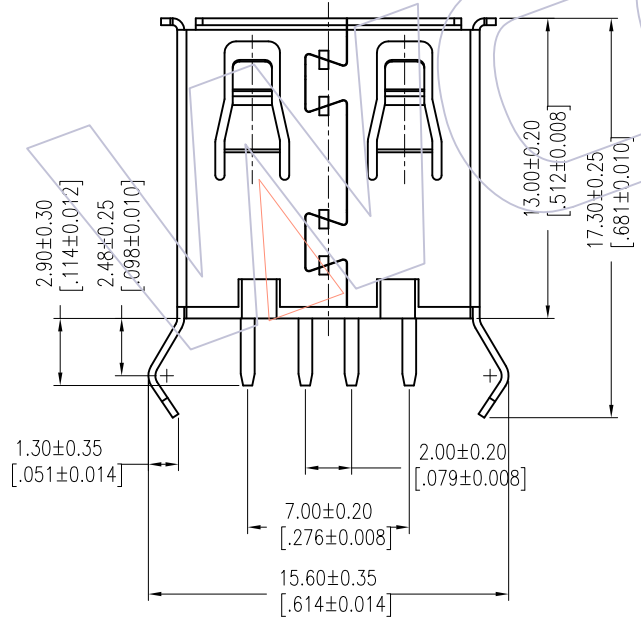
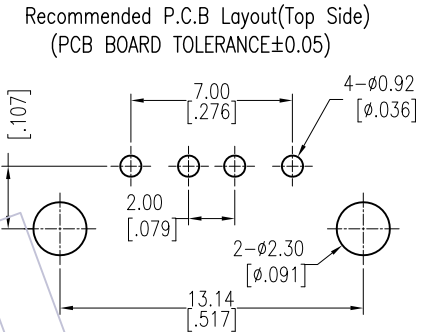
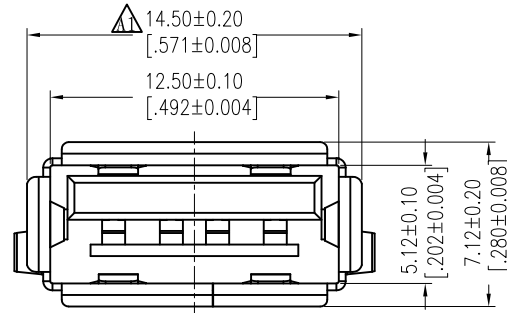
Contact Plating  Color Insulator Packing  
 S0=Gold Flash/Matte Tin B=Black A=Tray  
 S1=3u"Gold/Matte Tin  
 S2=5u"Gold/Matte Tin  
 S3=10u"Gold/Matte Tin  
 S4=15u"Gold/Matte Tin  
 S5=30u"Gold/Matte Tin



REV	DATE	MODIFICATION DESCRIPTION	CHANGE	OPERATION	DRAW	DATE	SCALE	FIT	PART NO.
A2	2015/07/27	Modify		X.X ±0.40	Allen	2015/07/27	UNIT	mm	6110-04AFSDXXBNA1
A1	2013/12/08	Modify the Dumenssion 14.30 to 14.50		X.XX ±0.25	CHECK	DATE	SIZE	A4	TITLE: USB A TYPE FEMALE 180° DIP L=13.0
AO	2012/02/15	NEW	-----	X.XXX ±0.15	APPROVE	DATE	SHEET	1/1	Customer NO.
				Angle ± 3'			PROJ.		
				DIM TOL					

# WCON

Http: www.wcon.com

WCON-Dongguan Tel: +86 769 85358920 Fax: +86 769 85358915 E-mail: sales@wcon.com  
 WCON-Kunshan Tel: +86 512 57468408 Fax: +86 512 57468468 E-mail: salesks@wcon.com