

# HSF

**NOTES:**

Rated Current:1.0AMP  
 Rated Voltage:125V AC/DC  
 Contact Resistance:20mΩ max  
 Withstand Voltage:250V AC/Minute  
 Insulation Resistance:100MΩ min  
 Operation Temperature: -25°C to +85°C

## Ordering Information

WF 1254 - T P G0 0 1

- Contact Plating
- G0=Gold Flash
- G1=3u"Gold
- G2=5u"Gold
- G3=10u"Gold
- G4=15u"Gold
- G5=30u"Gold
- S0=Gold Flash/Tin
- S1=3u"Gold/Tin
- S2=5u"Gold/Tin
- S3=10u"Gold/Tin
- S4=15u"Gold/Tin
- S5=30u"Gold/Tin
- SN=Tin

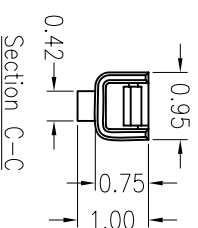
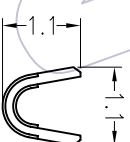
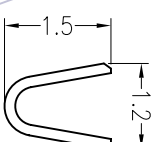
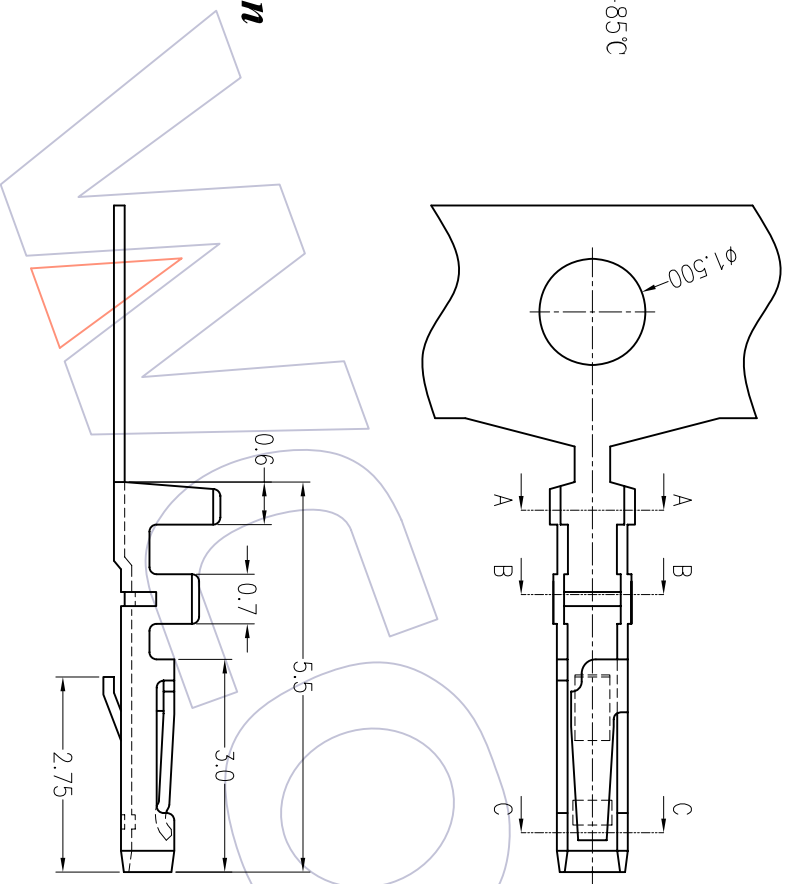

Specification & Ordering Information:

Part No.	Thickness	Material	Finish	Wire Range	Insulation O.D	Qty/Reel
WF1254-TPG001	0.15	Phosphor bronze	Gold Flash	AWG#28-#32	0.90mm Max.	20,000PCS

OPERATION	DRAW	William Chau	08.07.19	SCALE	1:1	 <b>WCON</b> 维峰五金电子有限公司 WAFER HARDWARE ELECTRONICS CO. LTD
DESIGN	CHECK	APPROVE	UNIT	mm	PART NO.	
DESIGN	CHECK	APPROVE	SIZE	A4	TITLE:	
ANGLE	± 3'	APPROVE	SHEET	1/1	CUSTOMER NO.	WF1254-TPXX01
ANGLE	± 3'	APPROVE	PROJ.			1.25 WAFER TERMINAL

REV	DATE	MODIFICATION DESCRIPTION	CHANGE	APPROVE	DIM	TOL
A0	08/07/19	NEW				