

HSF

NOTES:
 Rated Current:3.0AMP
 Contact Resistance:20mΩ max
 Withstand Voltage:1000V AC/DC
 Insulation Resistance:1000MΩ min
 Operation Temperature:-25℃ to +85℃

Contact Material:Phosphor bronze
 Contact Plating:Au Or Sn Over Ni

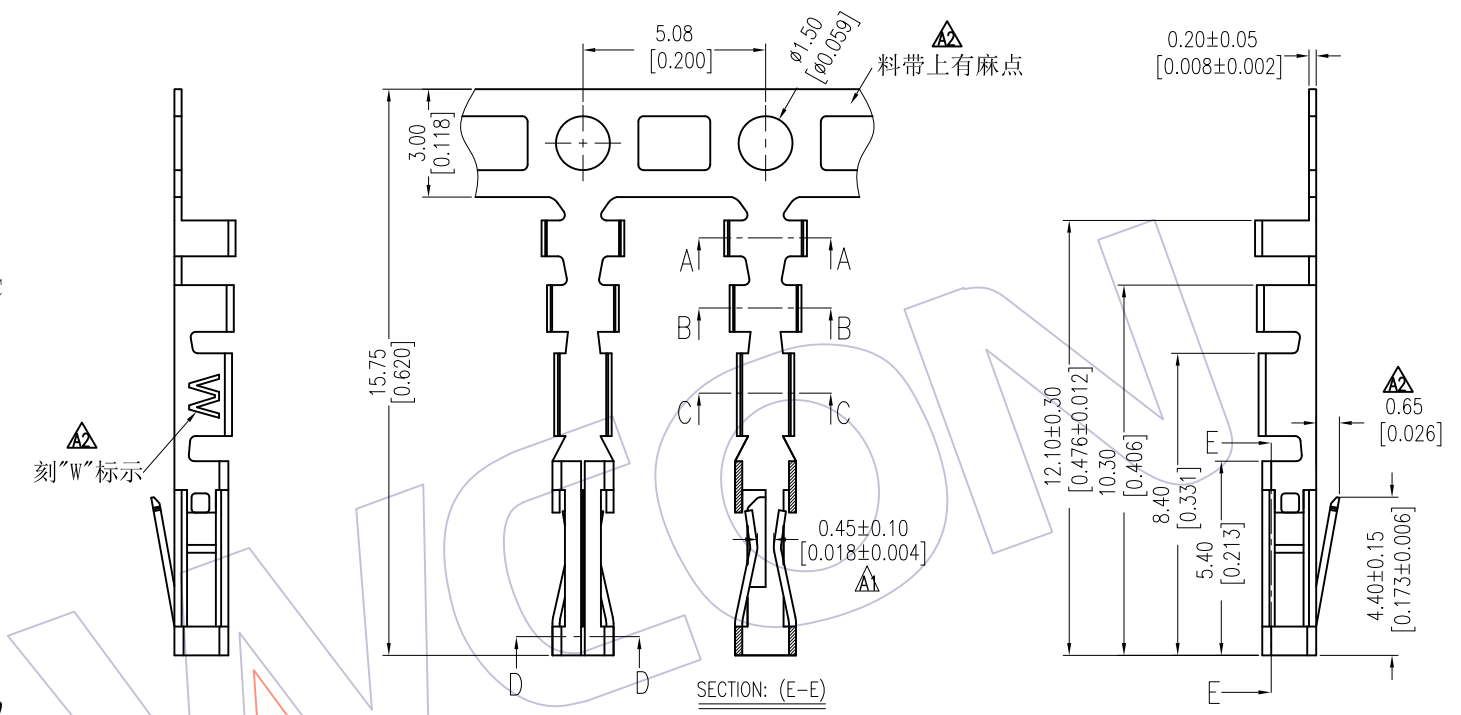

Ordering Information

WF2548-T P XX 0 1

Material
 P=Phosphor Bronze

Contact Plating
 S0=Gold Flash/Tin
 S3=10u"Gold/Tin
 S4=15u"Gold/Tin
 S5=30u"Gold/Tin
 SN=Tin
 G0=Gold Flash
 G3=10u"Gold
 G4=15u"Gold
 G5=30u"Gold

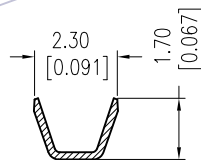

SECTION: (A-A)

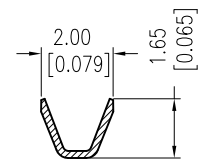

SECTION: (B-B)

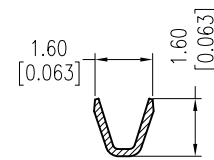

SECTION: (C-C)

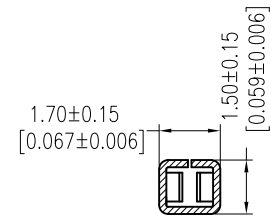

SECTION: (D-D)

Dimensional & Ordering Information

Part No.	Thickness	Finish	Material	Wire Range	Insulation O.D
WF2548-TPXX01	0.20	Tin	Phosphor Bronze	AWG#26~#22	1.55mm(Max)

REV	DATE	MODIFICATION DESCRIPTION	CHANGE	OPERATION	DRAW	DATE	SCALE	FIT	PART NO.
A2	2017/05/27	Modify	—	X.X ±0.40	Ding	2017/05/27	UNIT	mm inch	SEE TAB
A1	2012/12/24	Modify drawing	—	X.XX ±0.25	CHECK	DATE	SIZE	A4	TITLE: 2.54mm TERMINAL FEMALE
A0	2012/09/08	NEW	—	X.XXX ±0.15	APPROVE	DATE	SHEET	1/1	Customer NO.
				Angle DIM TOL			PROJ.		

WCON

Http: www.wcon.com

WCON-Dongguan Tel: +86 769 85358920 Fax: +86 769 85358915 E-mail: sales@wcon.com

WCON-Kunshan Tel: +86 512 57468408 Fax: +86 512 57468468 E-mail: salesks@wcon.com