

NOTES:

Current Rating:1.0AMP
 Contact Resistance:20mΩ max
 Withstand Voltage:500V AC/DC
 Insulation Resistance:500MΩ min
 Operation Temperature: -40°C to +85°C

Contact Material:Brass
 Contact plating:Au or Sn Over Ni
 Insulator Material:PA6T+30%G.F UL94V-0

Recommended P.C.B Layout(Top Side)
 (PCB BOARD TOLERANCE±0.05)

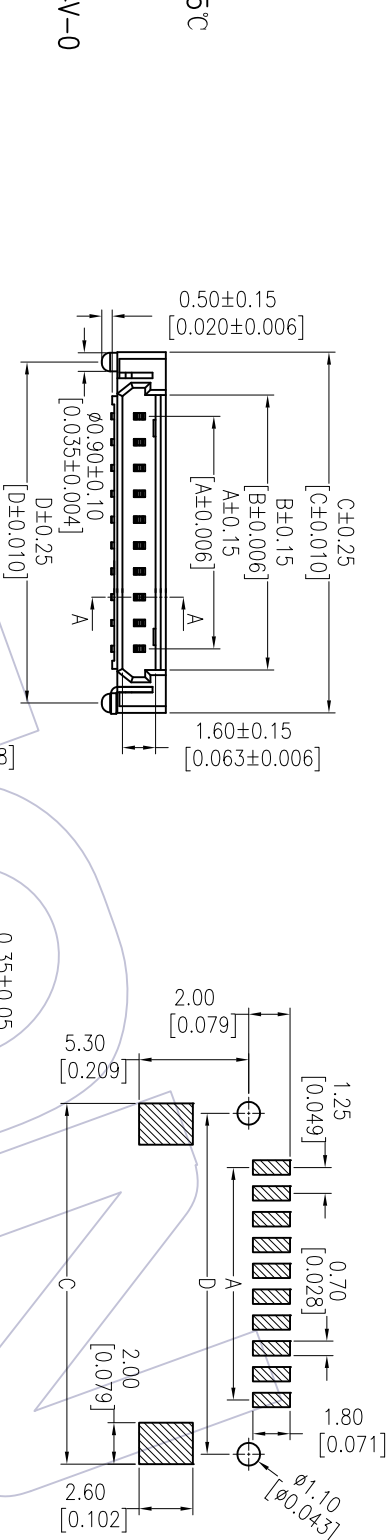

Ordering Information

WFI255 - WZ XX X T 1

Noof pins Contact Plating Color Packing
 02-30P SP=Gold Flash/Tin B=Black A=Tray
 T=Natural T=Tube
 F=Beige R=Reel
 W=White
 G0=Gold Flash G3=10μ"Gold G4=15μ"Gold G5=30μ"Gold Blank=Tin

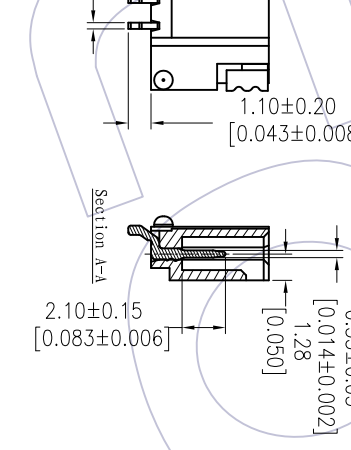
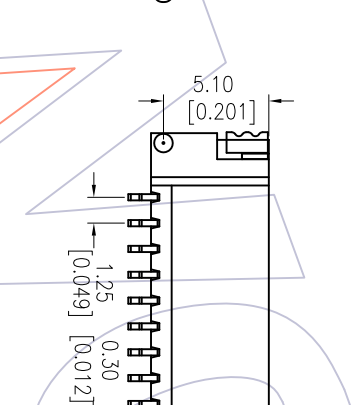
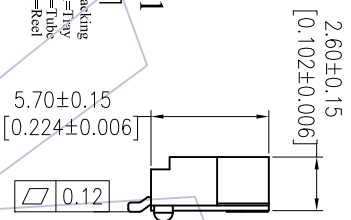

Specification & Ordering Information:

Circuit	Part No.	Dimension				Q'ty /Tube
		A	B	C	D	
02	WFI255-WZ02XT1	1.25	3.30	7.45	6.50	77
03	WFI255-WZ03XT1	2.50	4.55	8.70	7.75	66
04	WFI255-WZ04XT1	3.75	5.80	9.95	9.00	58
05	WFI255-WZ05XT1	5.00	7.05	11.20	10.25	51
06	WFI255-WZ06XT1	6.25	8.30	12.45	11.50	46
07	WFI255-WZ07XT1	7.50	9.55	13.70	12.75	42
08	WFI255-WZ08XT1	8.75	10.80	14.95	14.00	38
09	WFI255-WZ09XT1	10.00	12.05	16.20	15.25	35
10	WFI255-WZ10XT1	11.25	13.30	17.45	16.50	33
11	WFI255-WZ11XT1	12.50	14.55	18.70	17.75	31
12	WFI255-WZ12XT1	13.75	15.80	19.95	19.00	29
13	WFI255-WZ13XT1	15.00	17.05	21.20	20.25	27
14	WFI255-WZ14XT1	16.25	18.30	22.45	21.50	26
15	WFI255-WZ15XT1	17.50	19.55	23.70	22.75	24
16	WFI255-WZ16XT1	18.75	20.80	24.95	24.00	23
17	WFI255-WZ17XT1	20.00	22.05	26.20	25.25	22
18	WFI255-WZ18XT1	21.25	23.30	27.45	26.50	21
19	WFI255-WZ19XT1	22.50	24.55	28.70	27.75	20
20	WFI255-WZ20XT1	23.75	25.80	29.95	29.00	19
21	WFI255-WZ21XT1	25.00	27.05	31.20	30.25	18
22	WFI255-WZ22XT1	26.25	28.30	32.45	31.50	17
23	WFI255-WZ23XT1	27.50	29.55	33.70	32.75	17
24	WFI255-WZ24XT1	28.75	30.80	34.95	34.00	16
25	WFI255-WZ25XT1	30.00	32.05	36.20	35.25	16
26	WFI255-WZ26XT1	31.25	33.30	37.45	36.50	15
27	WFI255-WZ27XT1	32.50	34.55	38.70	37.75	14
28	WFI255-WZ28XT1	33.75	35.80	39.95	39.00	14
29	WFI255-WZ29XT1	35.00	37.05	41.20	40.25	14
30	WFI255-WZ30XT1	36.25	38.30	42.45	41.50	13



Http: www.wcon.com

WCON-Dongguan Tel: +86 512 57468408
 WCON-Kunshan Tel: +86 512 57468408

Tel: +86 769 85358920
 Fax: +86 769 85358915
 E-mail: sales@wcon.com

Tel: +86 512 57468408
 Fax: +86 512 57468468
 E-mail: sales@wcon.com

OPERATION	SCALE	FIT	DATE
X.X	mm	mm	2014/03/13
X.XX	A4		
X.XXX	1/1		

CHANGE	DESCRIPTION	DATE
A1	Modify The Material PA6T--PA6T	
A0	NEW	

REV	DATE	DESCRIPTION
A1	2014/03/13	Modify The Material PA6T--PA6T
A0	2012/08/25	NEW