

HSF

NOTES:

Current Rating: 1.0A AC/DC
Voltage Rating: 50V AC/DC
Temperature Range: -25°C to +85°C
Contact Resistance: 30mΩ Max.
Insulation Resistance: 100MΩ Min.
Withstanding Voltage: 500V AC/Minute

Material: Phosphor Bronze
Contact plating: Tin Over Ni
Insulation O.D.: $\phi 0.80$ to 1.0 mm (Max)
Wire Range: AWG#26

Ordering Information

WF1256-TP XX 01

Terminal Material
P: Phosphor Bronze

Contact Plating:
SN: Tin Plated

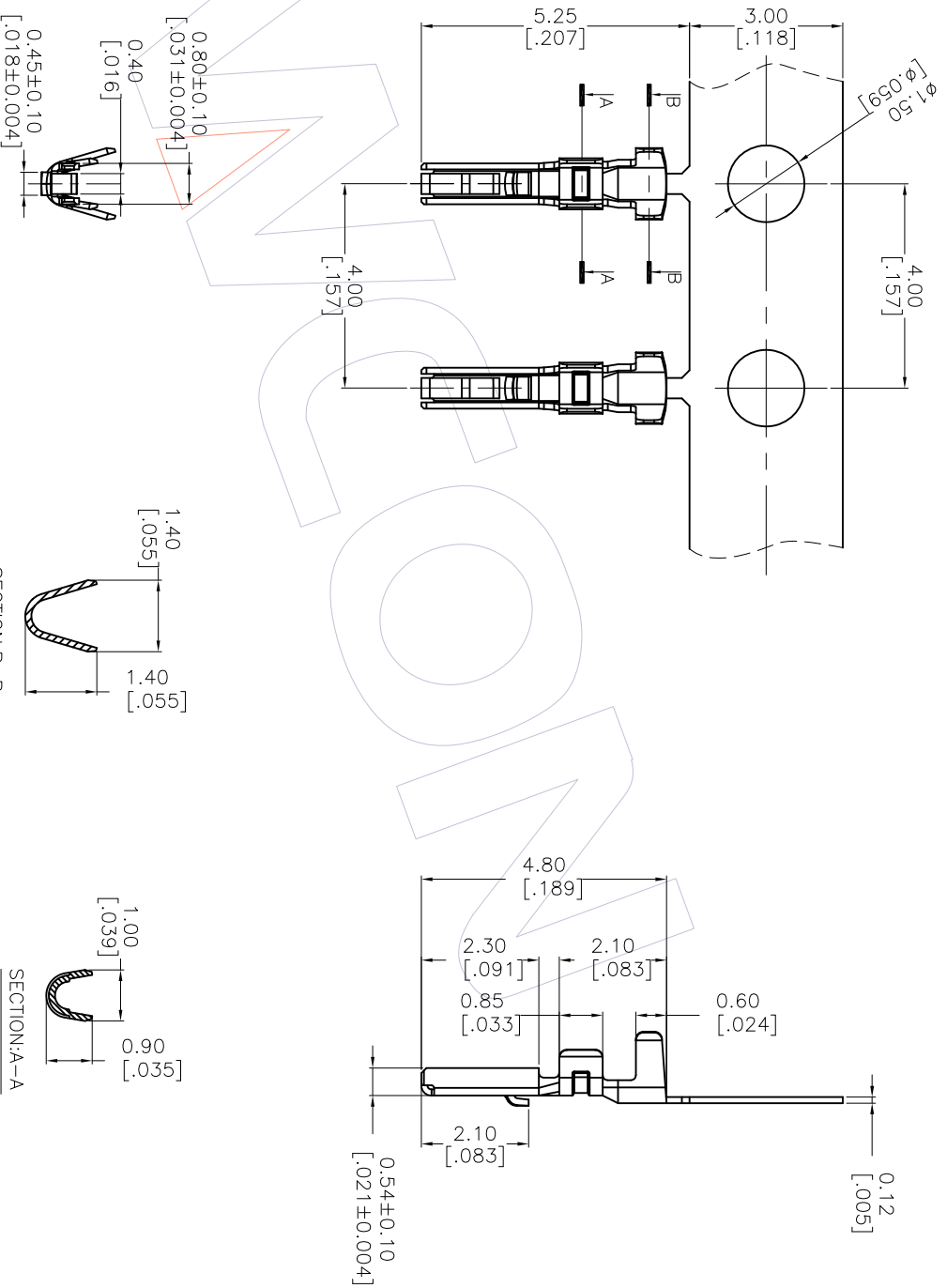

REV	DATE	MODIFICATION DESCRIPTION	CHANGE	OPERATION		DRAW		DATE	SCALE		PART NO.	TITLE:	WCON	
				X.XX	±0.40	LKP	LKP		2012.11.05	mm			inch	1.25mm Crimp Terminal
A0	2012.11.05	NEW	LKP	X.XXX	±0.25		CHECK	DATE	A4	1/1	Customer NO.		Tel: +86 769 85358920	Tel: +86 512 57468408
				Angle	±0.15		APPROVE	DATE	SHEET	1/1			Fax: +86 769 85358915	Fax: +86 512 57468468
				DIM	± 3				PROJ.				E-mail: sales@wcon.com	E-mail: sales@wcon.com

WCON

Http: www.wcon.com

WCON - Dongguan
Tel: +86 769 85358920
Fax: +86 769 85358915
E-mail: sales@wcon.com

WCON - Kunshan
Tel: +86 512 57468408
Fax: +86 512 57468468
E-mail: sales@wcon.com