

HSF

NOTES:

Rated Current:1.0AMP
 Rated Voltage:50V AC/DC
 Contact Resistance:20mΩ max
 Withstand Voltage:500V AC/Minute
 Insulation Resistance:500MΩ min
 Operation Temperature: -25℃ to +85℃

Ordering Information

WF 1501 - TP SN 01

- Contact Plating
- G0=Gold Flash
- G3=10u"Gold
- G4=15u"Gold
- G5=30u"Gold
- S0=Gold Flash/Tin
- S3=10u"Gold/Tin
- S4=15u"Gold/Tin
- S5=30u"Gold/Tin
- SN=Tin

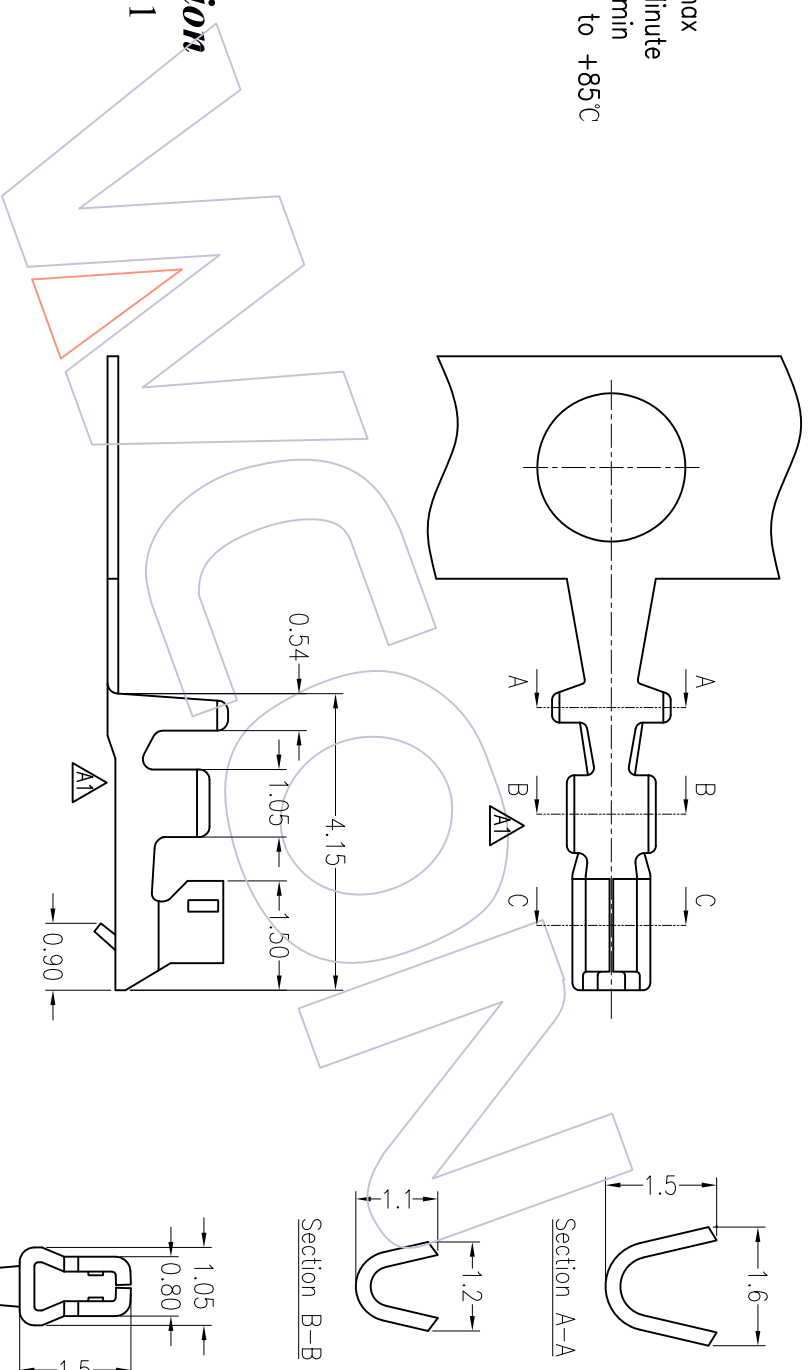

Part No.	Thickness	Material	Finish	Wire Range	Insulation O.D	Q'ty/Reel
WF1501-TPSN01	0.20	Phosphor bronze	Tin-Plated	AWG#28~#32	0.90mm Max.	15,000PCS

REV	DATE	MODIFICATION DESCRIPTION	CHANGE	OPERATION	DRAW	CHECK	APPROVE	DATE
A1	2014/01/16	Modify the drawing		X.X	JYhuong			2014/01/16
A0	2012/09/03	NEW		X.XXX				

SCALE	FIT	PART NO.	TITLE:	WCON-Dongguan	WCON-Kunshan
mm	mm	WF1501-TPXX01	ZH 1.50 WAFER TERMINAL	Tel: +86 769 85358920	Tel: +86 512 57468408
A4	1/1		Customer NO.	Fax: +86 769 85358915	Fax: +86 512 57468468
				E-mail: sdes@wcon.com	E-mail: sdes@wcon.com



Http: www.wcon.com

WCON-Dongguan
Tel: +86 769 85358920
Fax: +86 769 85358915
E-mail: sdes@wcon.com

WCON-Kunshan
Tel: +86 512 57468408
Fax: +86 512 57468468
E-mail: sdes@wcon.com