

HSF

NOTES:
 Rated Current:3.0AMP
 Contact Resistance:20mΩ max
 Withstand Voltage:1000V AC/DC
 Insulation Resistance:1000MΩ min
 Operation Temperature:-25℃ to +85℃

Insulator Material:PA66
 Use with:WF2549-T
 Mated With:WF2549-Wafer

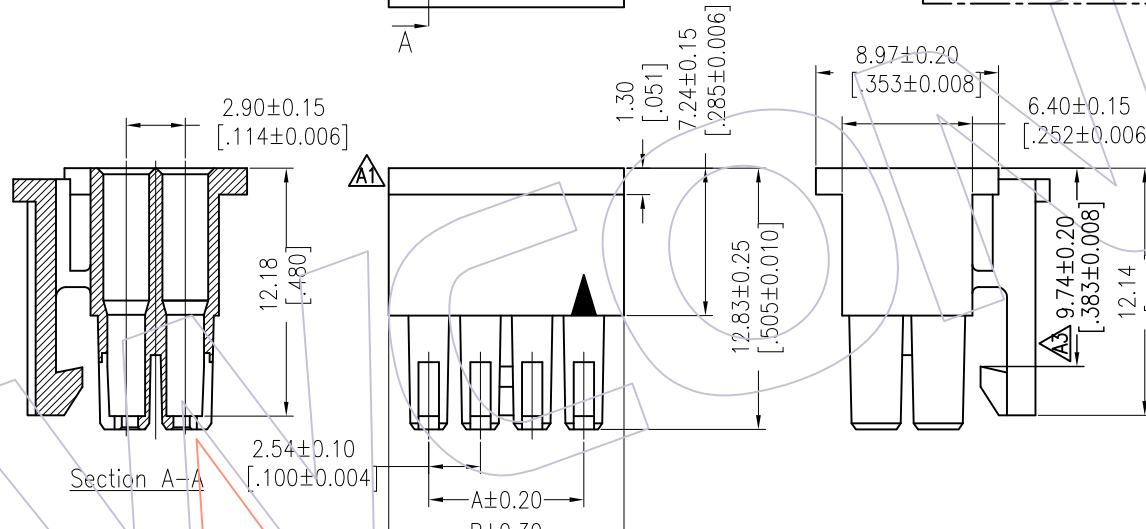
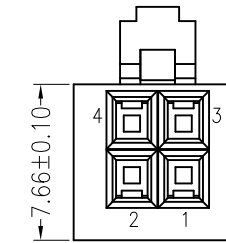
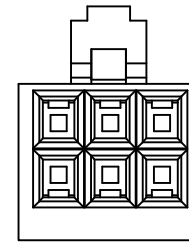
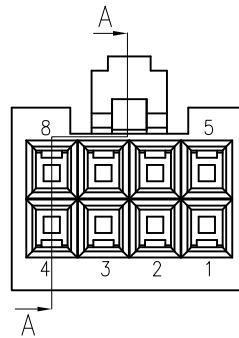

Ordering Information

WF2549- 2 H XX W 0 1

No. of Pins per Row: 02-25P
 Colour: W=White
 Packing: 0=PE Bag

Specification & Ordering Information:

Circuit	Part No.	Dimension	
		A	B
2x02	WF2549-2H02W01	2.54	8.26
2x03	WF2549-2H03W01	5.08	9.02
2x04	WF2549-2H04W01	7.62	11.56
2x05	WF2549-2H05W01	10.16	14.10
2x06	WF2549-2H06W01	12.70	16.64
2x07	WF2549-2H07W01	15.24	19.18
2x08	WF2549-2H08W01	17.78	21.72
2x09	WF2549-2H09W01	20.32	24.26
2x10	WF2549-2H10W01	22.86	26.80
2x11	WF2549-2H11W01	25.40	29.34
2x12	WF2549-2H12W01	27.94	31.88
2x13	WF2549-2H13W01	30.48	34.42
2x14	WF2549-2H14W01	33.02	36.96
2x15	WF2549-2H15W01	35.56	39.50
2x16	WF2549-2H16W01	38.10	42.04
2x17	WF2549-2H17W01	40.64	44.58
2x18	WF2549-2H18W01	43.18	47.12
2x19	WF2549-2H19W01	45.72	49.66
2x20	WF2549-2H20W01	48.26	52.20
2x21	WF2549-2H21W01	50.80	54.74
2x22	WF2549-2H22W01	53.34	57.28
2x23	WF2549-2H23W01	55.88	59.82
2x24	WF2549-2H24W01	58.42	62.36
2x25	WF2549-2H25W01	60.96	64.90

REV	DATE	MODIFICATION DESCRIPTION	CHANGE	OPERATION	OPERATION	DATE	SCALE	FIT	PART NO.
A3	2016/07/27	MODIFY DRAWING		OPERATION		2016/07/27			SEE TAB
A2	2013/05/10	ADD 2*03PIN ,2*02PIN DRAWING		X.X	±0.40		UNIT	mm	TITLE: 2.54mm HOUSING
A1	2013/02/19	MODIFY DRAWING		X.XX	±0.25		SIZE	A4	
AO	2012/09/10	NEW		X.XXX	±0.15		SHEET	1/1	Customer NO.
				Angle	± 3'		PROJ.		
				DIM	TOL				

WCON

Http: www.wcon.com

WCON-Dongguan Tel: +86 769 85358920
 WCON-Kunshan Tel: +86 512 57468408
 Fax: +86 769 85358915
 Fax: +86 512 57468468
 E-mail: sales@wcon.com
 E-mail: salesks@wcon.com