

HSF

NOTES:

Current Rating: 5.0AMP
 Contact Resistance: 20mΩ Max
 Withstand Voltage: 1500V AC/DC
 Insulation Resistance: 1000MΩ Min
 Operation Temperature: -25°C to +85°C

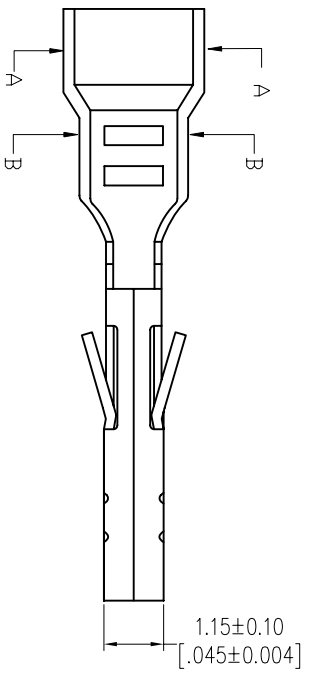

Ordering Information

WF 3001 - T X SN 0 1

Material Contact Plating
 P=Phosphor bronze SN=Tin
 B=Brass

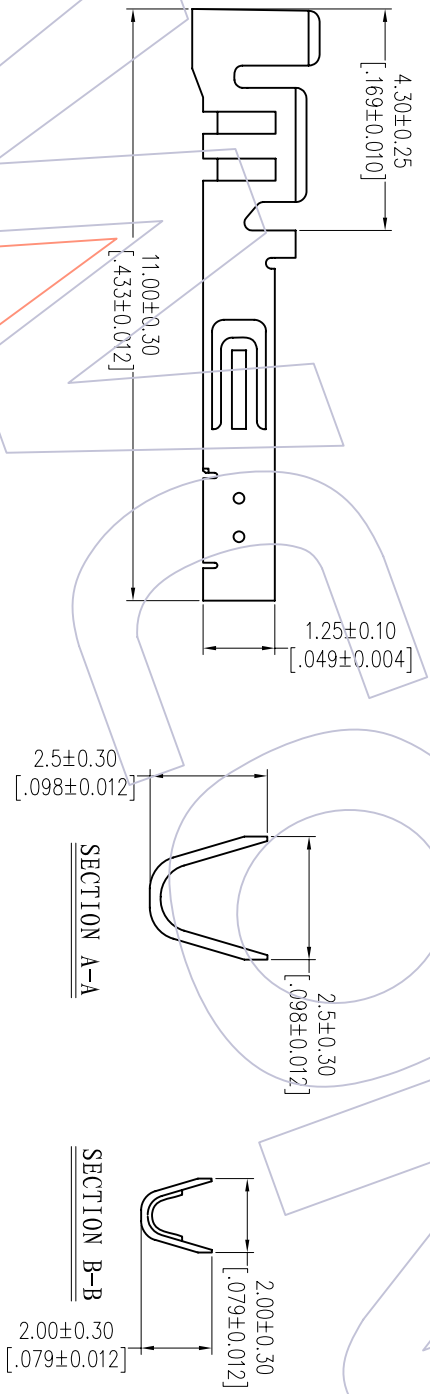

Specification & Ordering Information:

Part No.	Thickness	Material	Finish	Wire Range	Insulation O.D	Q'ty/Reel
WF3001-TPSN01	0.20	Phosphor bronze	Tin-Plated	AWG#20~#24	1.85mm Max.	10,000PCS
WF3001-TBSN01	0.20	Brass	Tin-Plated	AWG#20~#24	1.85mm Max.	10,000PCS

REV	DATE	MODIFICATION DESCRIPTION	CHANGE DIM	OPERATION	DRAW	DATE	SCALE	FIT	PART NO.	TITLE:	Customer NO.
A0	2012/09/28	NEW	-----	XX ±0.40	JYHuang	2012/09/28	mm	A4	SEE TABLE	3.00mm TERMINAL FEMALE	
				XXX ±0.25	CHECK	DATE	SIZE	1/1			
				XXX ±0.15		DATE	SHEET				
				Angle ± 3°	APPROVE	DATE	PROJ.				

WCON

Http: www.wcon.com
 WCON-Dongguan Tel: +86 769 85358920 Fax: +86 769 85358915 E-mail: sales@wcon.com
 WCON-Kunshan Tel: +86 512 57468408 Fax: +86 512 57468468 E-mail: sales@wcon.com