

NOTES:

- Current Rating: 5.0A AMP
- Contact Resistance: 10milliohm Max
- Withstand Voltage: 1000V AC/Minute
- Insulation Resistance: 1000Megohm Min
- Operation Temperature: -25°C to +85°C
- Housing Material: LCP+30%GF (UL94V-0)
- Contact Material: Copper alloy
- Contact plating: Au/Sn over Ni Plating

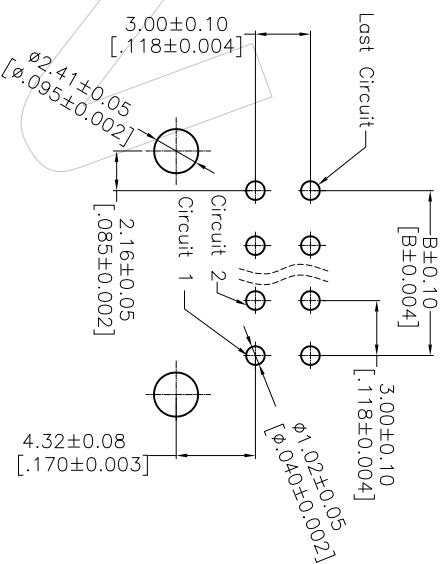
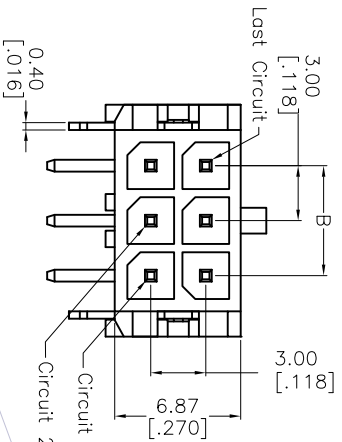

Ordering Information

WF3001-2 WR XX B X 2

Terminal shape: WR: Wafer 90° DIP
NO. of Pins Per Row: 01~12Pin
Packing: 0=PE Bag
T=Tube
A=Tray
R=Tray&Reel

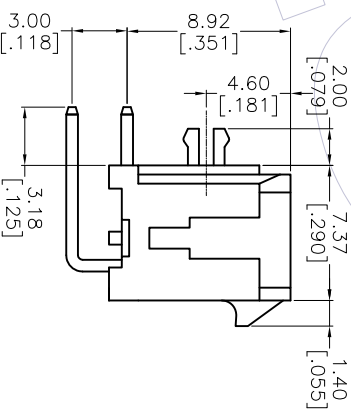
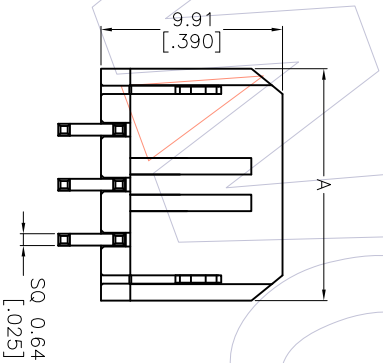

Circuit	A	B
02	6.65[0.262]	NA
04	9.65[0.380]	3.00[0.118]
06	12.65[0.498]	6.00[0.236]
08	15.65[0.616]	9.00[0.355]
10	18.65[0.735]	12.00[0.473]
12	21.65[0.853]	15.00[0.591]
14	24.65[0.971]	18.00[0.709]
16	27.65[1.089]	21.00[0.827]
18	30.65[1.207]	24.00[0.945]
20	33.65[1.325]	27.00[1.063]
22	36.65[1.443]	30.00[1.181]
24	39.65[1.561]	33.00[1.299]



Http: www.wcon.com

WCON - Dongguan
Tel: +86 769 8538920
Fax: +86 769 8535915
E-mail: sales@wcon.com

WCON - Kunshan
Tel: +86 512 57468408
Fax: +86 512 57468468
E-mail: sales@wcon.com

REV	DATE	MODIFICATION DESCRIPTION	CHANGE	OPERATION	DRAW	DATE	SCALE	PART NO.
A1	2012.05.04	料号由WF3001-2WRHXXBX2变更为WF3001-2WRXXXBX2	Atomy	X.XX ±0.40	FZY	2012.05.04	1:1 mm inch	△ WF3001-2WRXXXBX2
A0	2011.12.20	NEW	-	X.XXX ±0.15	CHECK	DATE	SIZE A4	TITLE: 3.00 WAFER DUAL ROW 90° DIP WITH CLIP
				Angle ± 3'	APPROVE	DATE	SHEET 1/1	Customer NO.
				DIM	TOL		PROJ.	