

NOTES:
 Rated Current: 2.5AMP
 Rated Voltage: 250V AC/DC
 Contact Resistance: 20mΩ max
 Withstand Voltage: 800V AC/Minute
 Insulation Resistance: 1000MΩ min
 Operation Temperature: -25°C to +95°C

Ordering Information

WF 2542 - T X XX 0 1

- Material
 P=Phosphor bronze
 B=Brass
- Contact Plating
 G0=Gold Flash
 G1=3μ"Gold
 G2=5μ"Gold
 G3=10μ"Gold
 G4=15μ"Gold
 G5=30μ"Gold
 S0=Gold Flash/Tin
 S1=3μ"Gold/Tin
 S2=5μ"Gold/Tin
 S3=10μ"Gold/Tin
 S4=15μ"Gold/Tin
 S5=30μ"Gold/Tin
 SN=1Tin

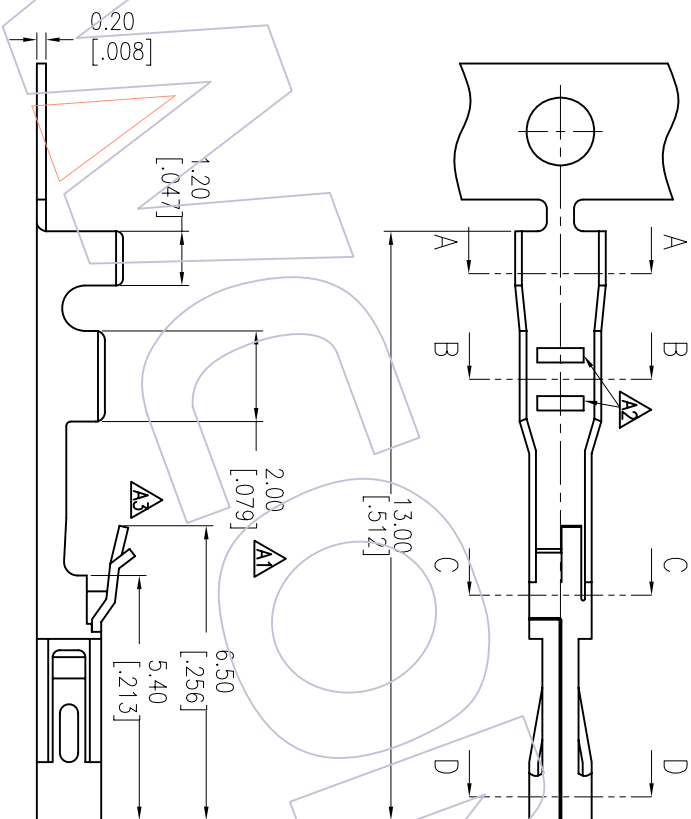

Specification & Ordering Information:

Part No.	Thickness	Material	Finish	Wire Range	Insulation O.D	Qty/Reel
WF2542-TPSN01	0.20	Phosphor bronze	Tin-Plated	AWG#24~#28	1.70mm Max.	10,000PCS
WF2542-TBSN01	0.20	Brass	Tin-Plated	AWG#24~#28	1.70mm Max.	10,000PCS

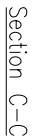
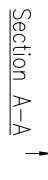

REV	DATE	MODIFICATION DESCRIPTION	CHANGE	OPERATION	DRAW	DATE	SCALE	FIT	PART NO.
A3	2012/05/14	Modify		X.X	JYHuang	2012/05/14	mm		WF2542-TXXX01
A2	2012/05/09	Modify drawing: 1.80--1.50		X.XX	CHECK	DATE	mm		
A1	2011/06/24	Modify drawing		X.XXX	CHECK	DATE	A4		
AO	2008/07/09	NEW		X.XXX	APPROVE	DATE	1/1		Customer NO.

OPERATION	DRAW	DATE	SCALE	FIT	PART NO.
±0.40	JYHuang	2012/05/14	mm		WF2542-TXXX01
±0.25	CHECK	DATE	mm		
±0.15	CHECK	DATE	A4		
± 3'	APPROVE	DATE	1/1		Customer NO.

WCON
 Http: www.wcon.com

WCON-Dongguan
 Tel: +86 769 85358920
 Fax: +86 769 85358915
 E-mail: sales@wcon.com

WCON-Kunshan
 Tel: +86 512 57468408
 Fax: +86 512 57468468
 E-mail: sales@wcon.com