

HSF

NOTES:
 Rated Current: 3.0AMP
 Contact Resistance: 20mΩ max
 Withstand Voltage: 1000V AC/DC
 Insulation Resistance: 1000MΩ min
 Operation Temperature: -25°C to +85°C

Ordering Information

WF2543 - T X XX 01

Material
 B=Brass
 P=Phosphor bronze

Contact Plating:
 G0=Gold Flash
 G3=10µ"Gold
 G4=15µ"Gold
 G5=30µ"Gold
 S0=Gold Flash/Tin
 S3=10µ"Gold/Tin
 S4=15µ"Gold/Tin
 S5=30µ"Gold/Tin
 SN=Tin

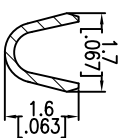
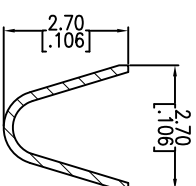
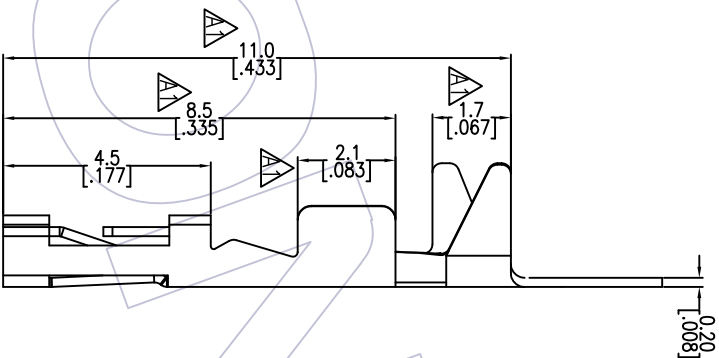
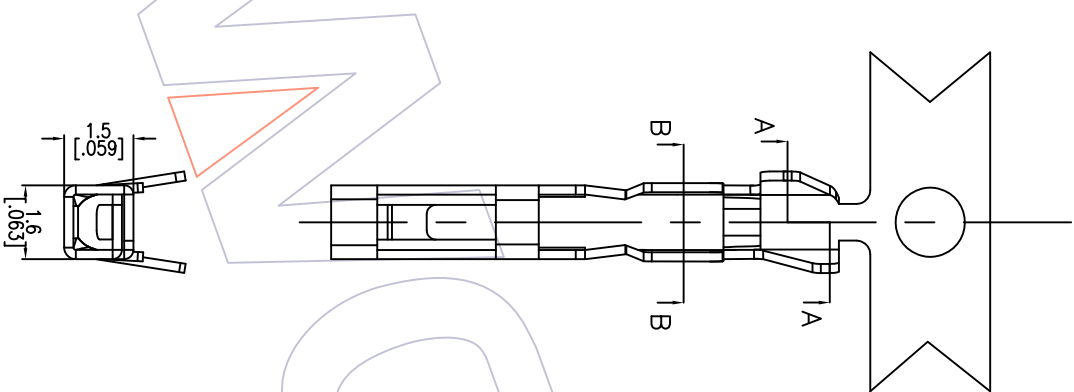

Specification & Ordering Information:

Part No.	Thickness	Finish	Material	Wire Range	Insulation O.D	Q'ty/Reel
WF2543-TXSX01	0.20	Tin-Plated	Phosphor bronze/Brass	AWG#22~#28	1.60mm(Max.)	10,000pcs
WF2543-TXGX01	0.20	Gold-Plated	Phosphor bronze/Brass	AWG#22~#28	1.60mm(Max.)	10,000pcs

REV	DATE	MODIFICATION DESCRIPTION	CHANGE
A1	2014/02/19	Modify The Dim	
A0	2012/09/08	NEW	

OPERATION	DRAW	DATE	SCALE	FIT	PART NO.
X.X	JYHuang	2014/02/19	mm		SEE TAB
X.XX	CHECK	DATE	UNIT		TITLE:
X.XXX	APPROVE	DATE	SIZE	A4	2.54 TERMINAL
Angle			SHEET	1/1	Customer NO.
DIM			PROJ.		

WCON

Http: www.wcon.com

WCON-Dongguan

WCON-Kunshan

Tel: +86 769 85358920
 Fax: +86 769 85358915
 E-mail: sales@wcon.com

Tel: +86 512 57468408
 Fax: +86 512 57468468
 E-mail: sales@wcon.com