

HSF

NOTES:
Current Rating:3.0A
Voltage Rating:250V AC,DC
Contact Resistance:20mΩ max
Withstand Voltage:1000V AC/minute
Insulation Resistance:1000MΩ min
Operation Temperature:-25°C to +85°C

Ordering Information

WF2541 - T X XX 01

Material
B=Brass
P=Phosphor bronze

Contact Plating:
G0=Gold Flash
G3=10μ"Gold
G4=15μ"Gold
G5=30μ"Gold
S0=Gold Flash/Tin
S3=10μ"Gold/Tin
S4=15μ"Gold/Tin
S5=30μ"Gold/Tin
SN=Tin

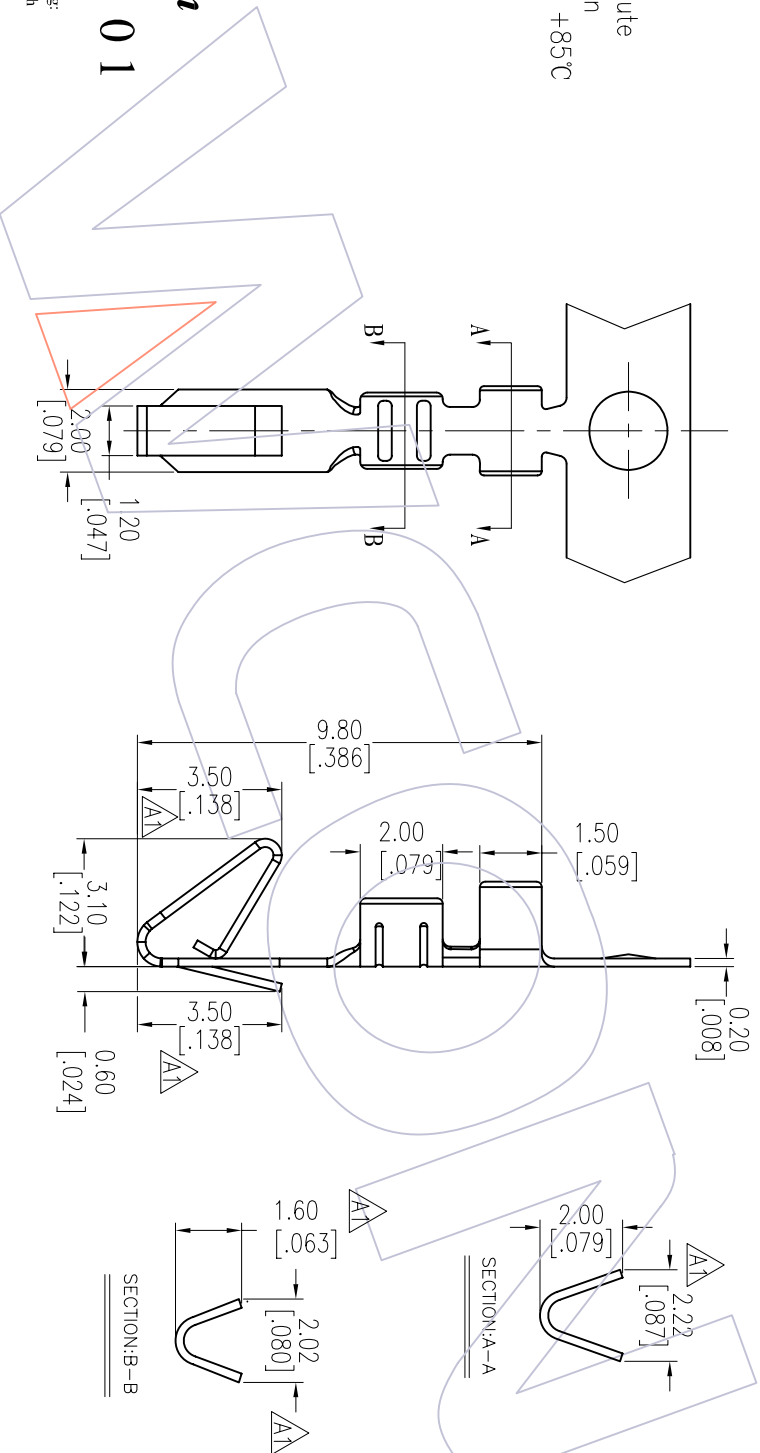

Specification & Ordering Information:

Part No.	Thickness	Material	Finish	Wire Range	Insulation O.D	Q'ty/Reel
WF2541-TXSN01	0.20	Phosphor bronze/Brass	Tin-Plated	AWG#22~#28	1.50mm(Max)	10,000PCS

OPERATION	DRAW	DATE	SCALE	FIT	PART NO.	WCON - Dongguan Http: www.wcon.com	WCON - Kunshan
XX	JYhuong	2012/12/19	mm	mm	SEE TAB		
CHECK	CHECK	DATE	SIZE	A4	TITLE:	Tel: +86 769 85358920	Tel: +86 512 57468408
XX.XXX	XX.XXX	DATE	1/1	PROJ.	"M"TYPE 2.54 TERMINAL	Fax: +86 769 85358915	Fax: +86 512 57468468
Angle	APPROVE	DATE	1/1	Customer NO.		E-mail: sdes@wcon.com	E-mail: sdesks@wcon.com
± 3'							
DIM	TOL						

WCON

REV	DATE	MODIFICATION DESCRIPTION	CHANGE
A1	2012/12/19	MODIFY THE DIM	
A0	2012/09/07	NEW	

1 2 3 4 5 6 7 8 9 10

A B C D E F G H

1 2 3 4 5 6 7 8 9 10

A B C D E F G H