

HSF

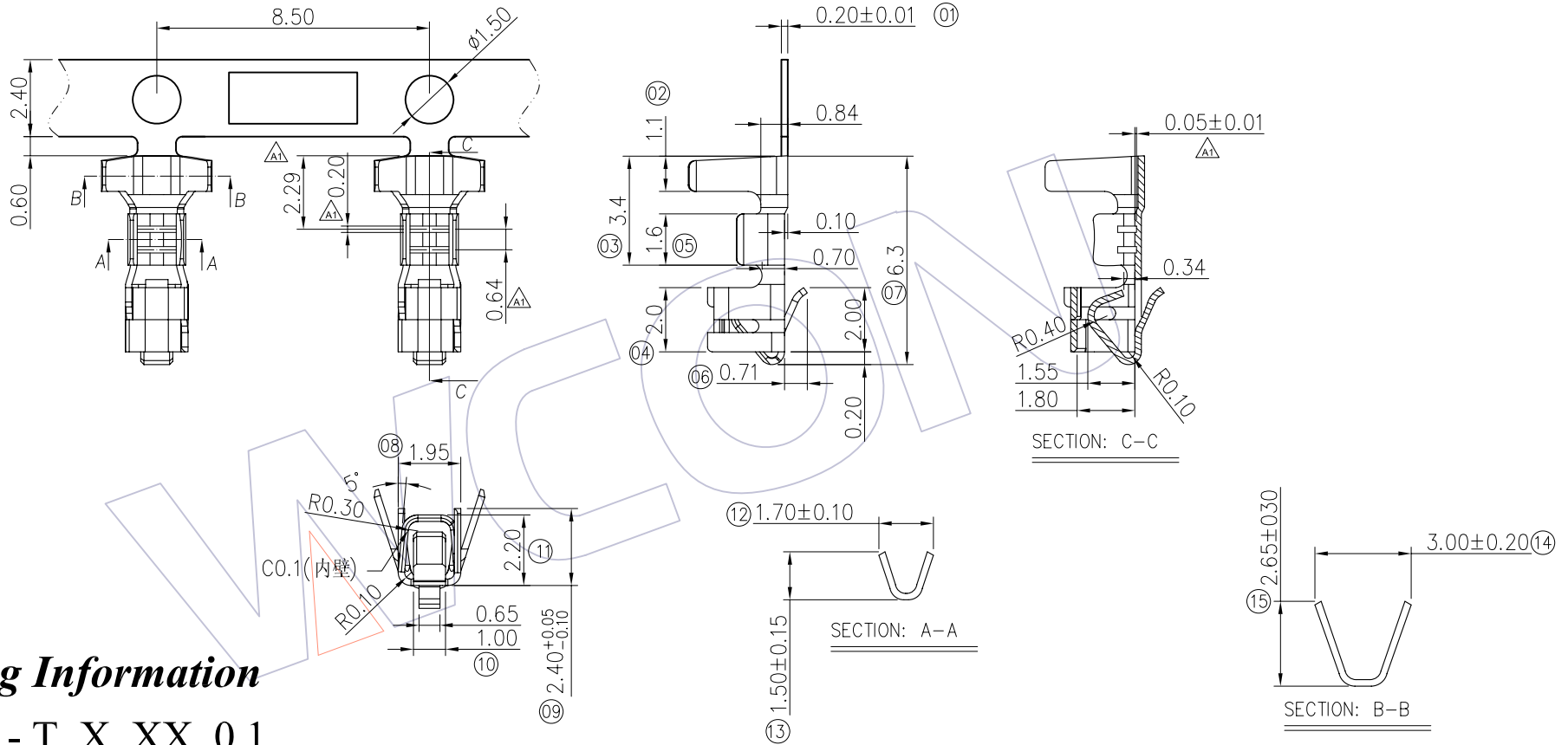

Ordering Information

WF2501 - T X XX 0 1

Material
B=Brass
P=Phosphor bronze

Contact Plating:
G0=Gold Flash
S0=Gold Flash/Tin
SN=Tin

Dimensional & Ordering Information

Part No.	Thickness	Thickness	Finish	Wire Range	Insulation O.D	Q'ty/Reel
WF2501-TPSN01	0.20	Phosphor bronze	Tin-Plated	AWG#22~#28	1.90mm(Max.)	8,000PCS
WF2501-TBSN01	0.20	Brass	Tin-Plated	AWG#22~#28	1.90mm(Max.)	8,000PCS

REV	DATE	MODIFICATION DESCRIPTION	CHANGE	OPERATION		DRAW JYHuang	DATE 2012/05/15	SCALE UNIT mm	FIT mm	PART NO. WF2501-TXXX01	TITLE: J-XH 2.50 TERMINAL	 Http: www.wcon.com	
				X.X	±0.40								
A1	2012/05/15	Modify drawing	---	X.XX	±0.25	CHECK	DATE	SIZE A4		Customer NO.			
A0	2012/02/24	NEW	---	X.XXX	±0.15	APPROVE	DATE	SHEET 1/1					
				Angle	± 3'			PROJ.					