

HSF

NOTES:

Rated Current:1.0A
 Rated Voltage:100V AC/DC
 Contact Resistance:20mΩ max
 Withstand Voltage:250V AC/Minute
 Insulation Resistance:500MΩ min
 Operation Temperature: -25°C to+85°C

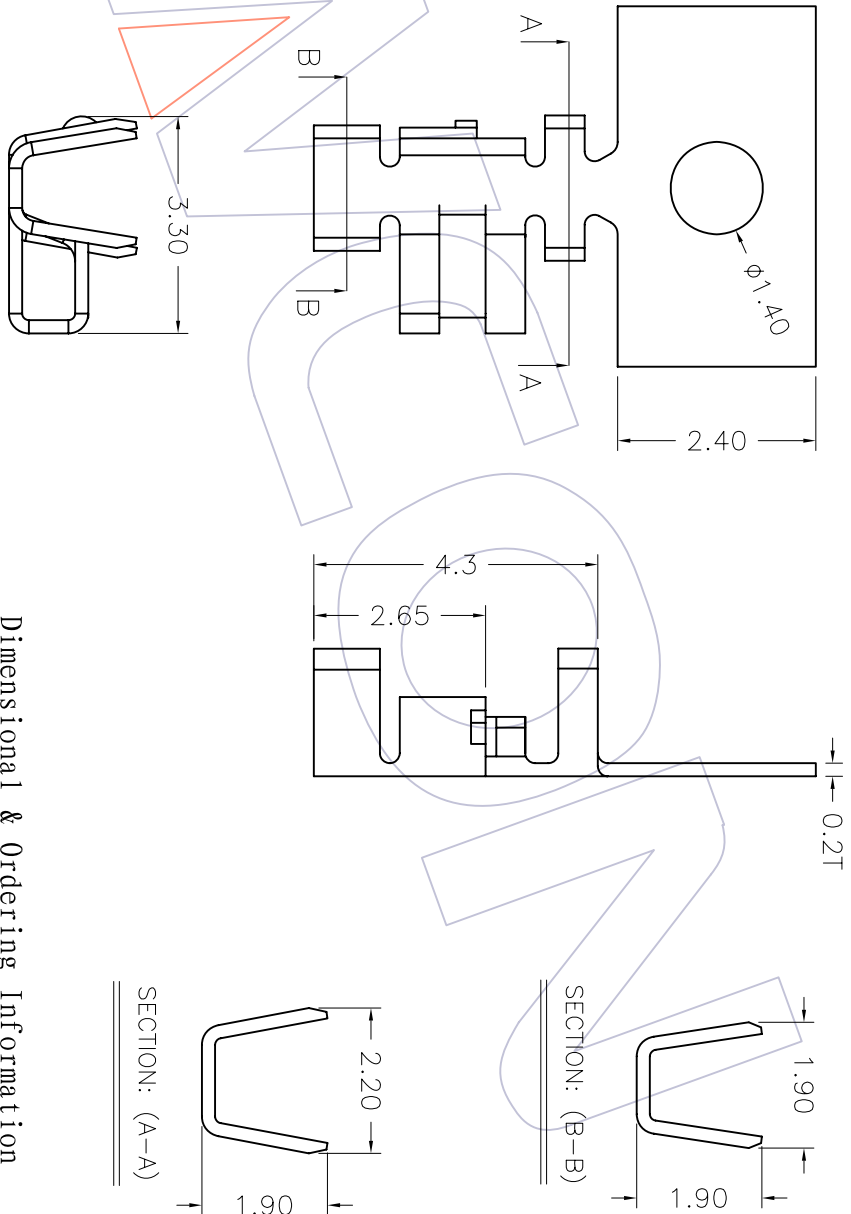

Ordering Information

WF2006 - TP XX 01

- Contact Plating:
- G0=Gold Flash
 - G1=3μ"Gold
 - G2=5μ"Gold
 - G3=10μ"Gold
 - G4=15μ"Gold
 - G5=30μ"Gold
 - S0=Gold Flash/Tin
 - S1=3μ"Gold/Tin
 - S2=5μ"Gold/Tin
 - S3=10μ"Gold/Tin
 - S4=15μ"Gold/Tin
 - S5=30μ"Gold/Tin
 - SN=Tin

Dimensional & Ordering Information

Part No.	Thickness	Finish	Material	Wire Range
WF2006-TPSN01	0.20	Tin-Plated	Phosphor bronze	AWG#22~#28
WF2006-TPGG001	0.20	Gold-Plated	Phosphor bronze	AWG#22~#28

WCON 维峰五金电子有限公司
 WAFER HARDWARE ELECTRONICS CO.,LTD

OPERATION	DRAW	WEIXD	SCALE	PART NO.
X.X	DESIGN	08/08/04	1:1	
X.XX	CHECK		mm	
X.XXX	CHECK		A4	
Angle	APPROVE		1/1	TITLE:
± 3'			PROJ.	Customer NO.

REV	DATE	MODIFICATION DESCRIPTION	CHANGE	APPROVE
A0	08/08/04	NEW		