

HSP

NOTES:

Current Rating: 3.0A
 Voltage Rating: 250V AC,DC
 Contact Resistance: 20mΩ max
 Withstand Voltage: 800V AC/minute
 Insulation Resistance: 1000MΩ min
 Operation Temperature: -25°C to +85°C

Ordering Information

WF2504 - T P XX 01

Material
 B=Brass
 P=Phosphor bronze

Contact Plating:
 G0=Gold Flash
 G3=10µ"Gold
 G4=15µ"Gold
 G5=30µ"Gold
 S0=Gold Flash/Tin
 S3=10µ"Gold/Tin
 S4=15µ"Gold/Tin
 S5=30µ"Gold/Tin
 SN=Tin

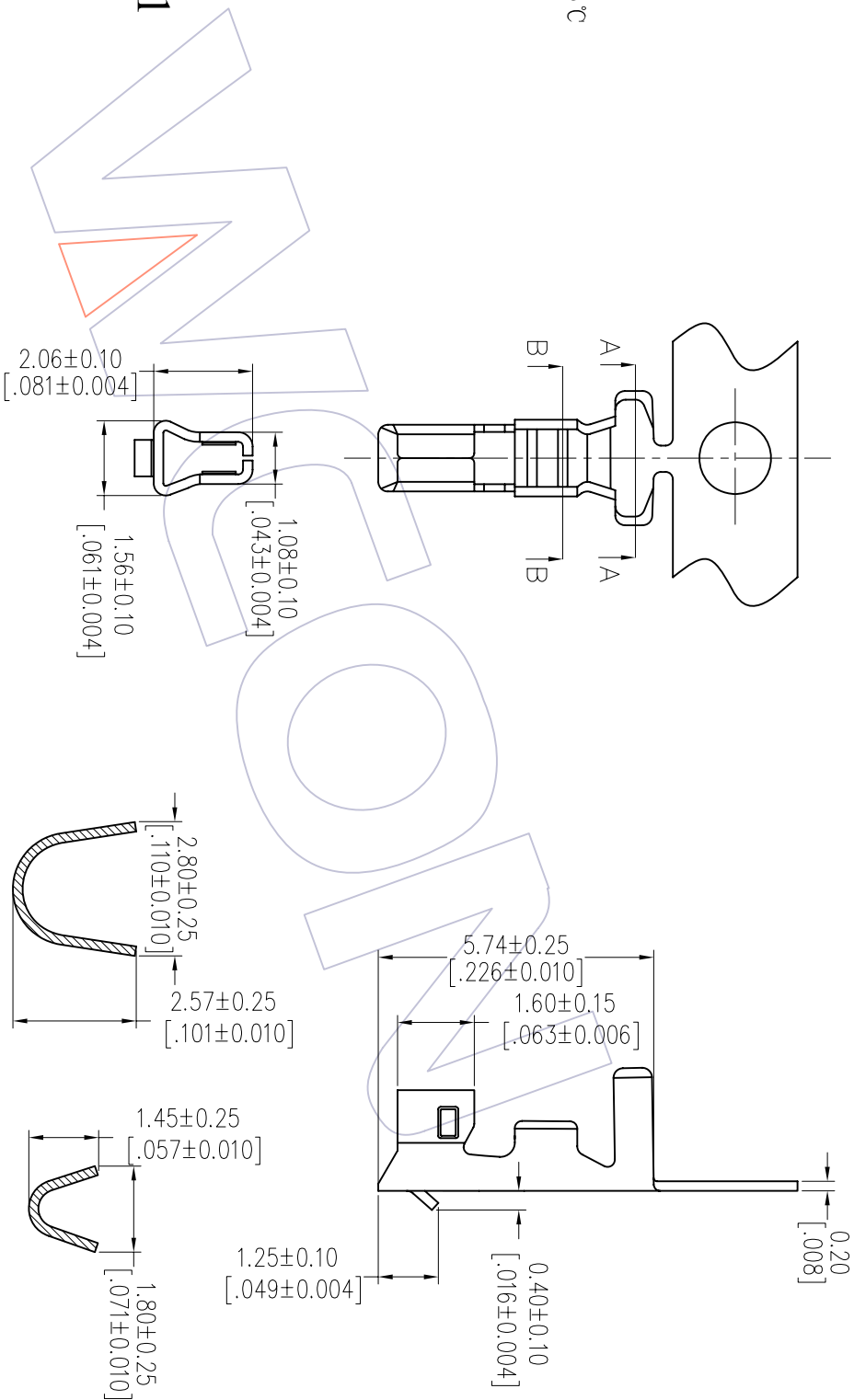

Specification & Ordering Information:

Part NO.	Thickness	Material	Finish	Wire Range	Insulation O.D.	Q'ty/Reel
WF2504-TPXX01	0.20	Phosphor Bronze	Tin-Plated	AWG #22~#30	1.13~1.60mm	1,000pcs

OPERATION	XX	±0.40
CHECK	XXX	±0.25
Angle	XXX	±0.15
DIM		± 3°

DRAW	JYHuang	DATE	2012/09/06
CHECK		DATE	
APPROVE		DATE	

SCALE	UNIT	FIT
1/1	mm	1/1

PART NO.	SEE TAB
TITLE:	EH PH2.50 TERMINAL
CUSTOMER NO.	

WCON

Http: www.wcon.com

WCON-Dongguan
 Tel: +86 769 85358920
 Fax: +86 769 85358915
 E-mail: sales@wcon.com

WCON-Kunshan
 Tel: +86 512 57468408
 Fax: +86 512 57468468
 E-mail: sales@wcon.com

REV	DATE	MODIFICATION DESCRIPTION	CHANGE
AO	2012/09/06	NEW	