

HSF

NOTES:

Rated Current:3.0A
 Rated Voltage:250V AC/DC
 Contact Resistance:20mΩ max
 Withstand Voltage:1000V AC/Minute
 Insulation Resistance:1000MΩ min
 Operation Temperature:-25℃ to+85℃

Contact Plating:
 G0=Gold Flash
 G1=3μ"Gold
 G2=5μ"Gold
 G3=10μ"Gold
 G4=15μ"Gold
 G5=30μ"Gold
 S0=Gold Flash/Tin
 S1=3μ"Gold/Tin
 S2=5μ"Gold/Tin
 S3=10μ"Gold/Tin
 S4=15μ"Gold/Tin
 S5=30μ"Gold/Tin
 SN=1Tin

Ordering Information

WF2505 - TP **XX** 01

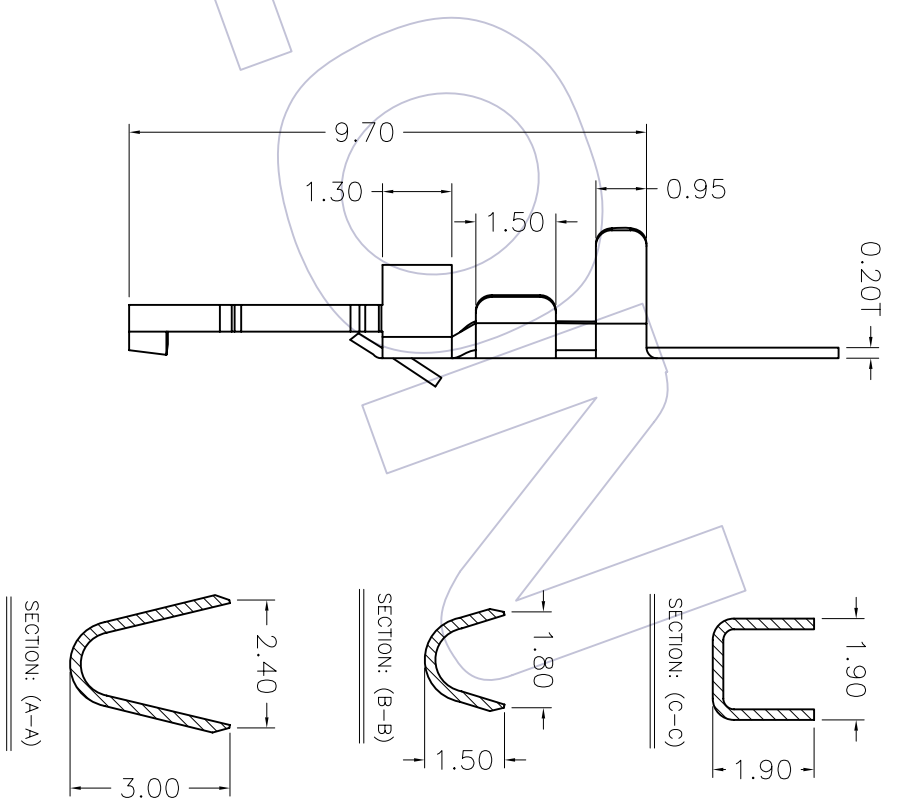
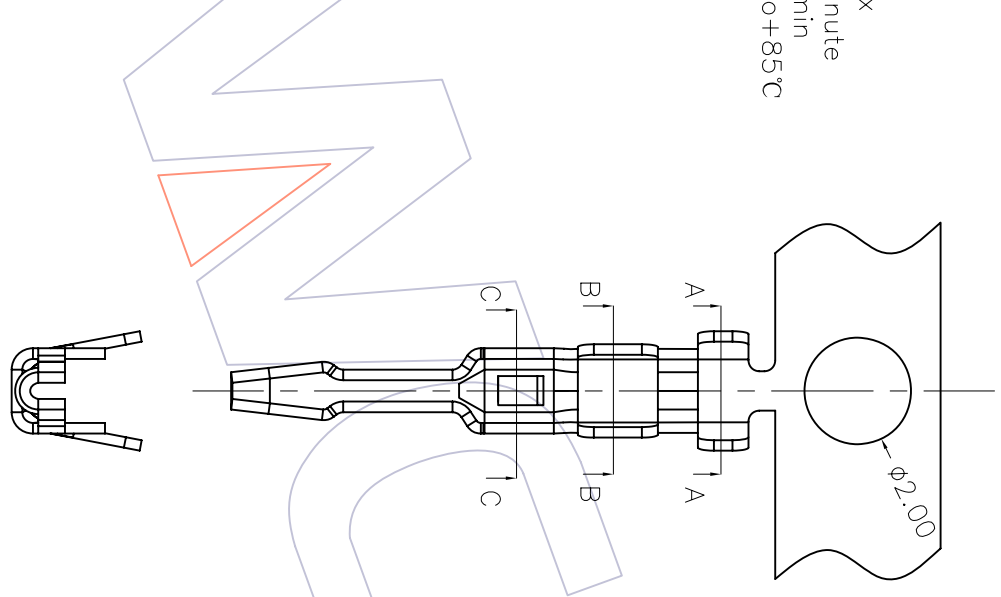

Dimensional & Ordering Information

Part No.	Thickness	Finish	Material	Wire Range	Insulation O.D
WF2505-TPSN01	0.20	Tin-Plated	Phosphor bronze	AWG#22~#28	1.90mm(Max)
WF2505-TPG001	0.20	Gold-Plated	Phosphor bronze	AWG#22~#28	1.90mm(Max)

WCON 维峰五金电子有限公司
 WAFER HARDWARE ELECTRONICS CO.,LTD

OPERATION	DRAW	WEIXD	SCALE	PART NO.	SEE TAB
XXX	DESIGN	08/08/04	1:1		
XXX	CHECK		mm		
XXX	CHECK		A4		
Angle	APPROVE		SHEET	TITLE:	2.50 TERMINAL
± .3°			PROJ.	Customer NO.	

REV	DATE	MODIFICATION DESCRIPTION	CHANGE	APPROVE
A0	08/07/04	NEW		