

HSF

NOTES:

Rated Current:3.0A
 Rated Voltage:250V AC/DC
 Contact Resistance:20mΩ max
 Withstand Voltage:800V AC/Minute
 Insulation Resistance:500MΩ min
 Operation Temperature:-25°C to+85°C

Contact Material:Brass
 Contact Plating:Sn over Ni
 Insulator Material:High Temperature Plastic(UL94V-0)

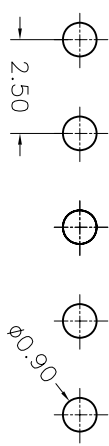
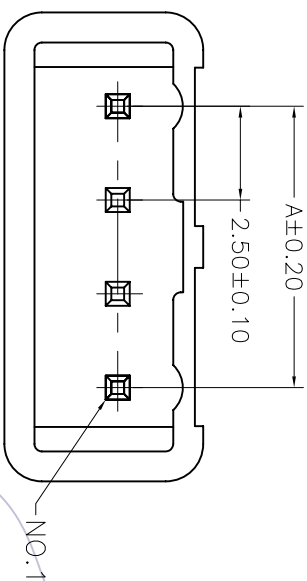

Ordering Information

WF2511 -WS XX X X 1

No. of pins: 02P-15P
 Color: E=Beige, W=White, B=Black
 Packing: 0=PE Bag, T=Tube

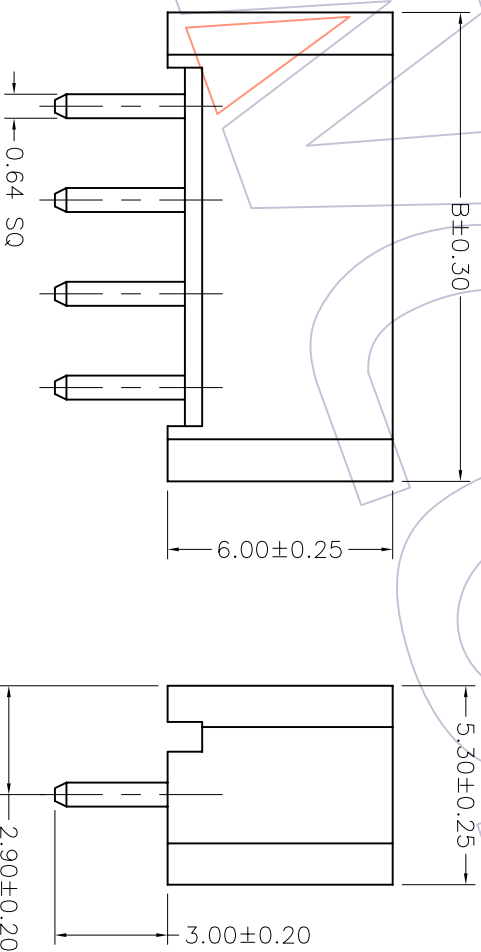

Dimensional & Ordering Information

Circuit	Part No.	Dimension	
		A	B
02	WF2511-WS02XX1	2.50	7.50
03	WF2511-WS03XX1	5.00	10.00
04	WF2511-WS04XX1	7.50	12.50
05	WF2511-WS05XX1	10.00	15.00
06	WF2511-WS06XX1	12.50	17.50
07	WF2510-WS07XX1	15.00	20.00
08	WF2511-WS08XX1	17.50	22.50
09	WF2511-WS09XX1	20.00	25.00
10	WF2511-WS10XX1	22.50	27.50
11	WF2511-WS11XX1	25.00	30.00
12	WF2511-WS12XX1	27.50	32.50
13	WF2511-WS13XX1	30.00	35.00
14	WF2511-WS14XX1	32.50	37.50
15	WF2511-WS15XX1	35.00	40.00

WCON 维峰五金电子有限公司
 WAVE HARDWARE ELECTRONICS CO. LTD

OPERATION	DRAW	WEIXD	SCALE	PART NO.
X.X	DESIGN		1:1	SBE TAB
X.XX	CHECK		mm	
X.XXX	APPROVE		A4	
Angle			1/1	TITLE:
± 3'			PROJ.	Customer NO.

REV	DATE	MODIFICATION DESCRIPTION	CHANGE	APPROVE	DIM	TOL	APPROVE
A0	08/08/04	NEW					

1	2	3	4	5	6	7	8	9	10
---	---	---	---	---	---	---	---	---	----