

# HSF

NOTES:  
 Rated Current:3.0A  
 Rated Voltage:250V AC/DC  
 Contact Resistance:20mΩ max  
 Withstand Voltage:800V AC/Minute  
 Insulation Resistance:500MΩ min  
 Operation Temperature: -25°C to+85°C

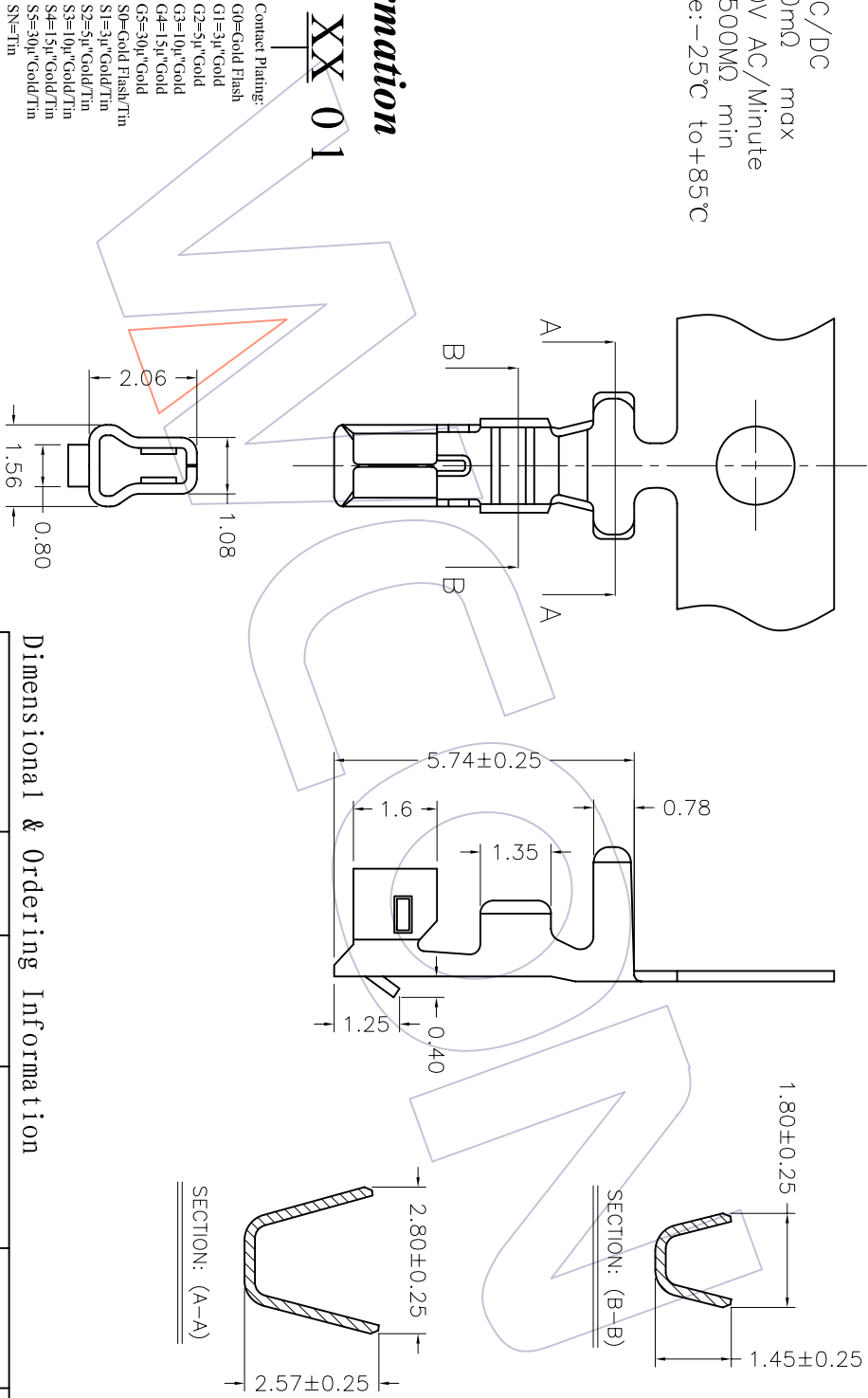

## Ordering Information

### WF2511 - TTP **XX** 01

- Contact Plating:
- G0=Gold Flash
  - G1=3μ"Gold
  - G2=5μ"Gold
  - G3=10μ"Gold
  - G4=15μ"Gold
  - G5=30μ"Gold
  - S0=Gold Flash/Tin
  - S1=3μ"Gold/Tin
  - S2=5μ"Gold/Tin
  - S3=10μ"Gold/Tin
  - S4=15μ"Gold/Tin
  - S5=30μ"Gold/Tin
  - SN=Tin

### Dimensional & Ordering Information

Part No.	Thickness	Finish	Material	Wire Range	Insulation O.D	Q'ty/Reel
WF2511-TPG001	0.20	Gold-flash	Phosphor bronze	AWG#22~#30	1.90mm(Max)	10,000pcs
WF2511-TPSN01	0.20	Tin-Plated	Phosphor bronze	AWG#22~#30	1.90mm(Max)	10,000pcs

OPERATION	XX	±0.25	DRAW	WEIXD	08/08/04	SCALE	1:1	PART NO.	SEE TAB
	XXX	±0.15		DESIGN	UNIT		mm		
ANGLE	XXX	±0.10	CHECK	SHEET	1/1	TITLE:	Customer NO.		
	Angle	± 3'			APPROVE			PROJ.	
REV	A0	08/08/04	NEW	MODIFICATION DESCRIPTION	CHANGE	APPROVE			
DATE									

**WCON** 维峰五金电子有限公司  
 WAVE HARDWARE ELECTRONICS CO., LTD

2.50 TERMINAL