

# HSF

NOTES:  
 Current Rating: 5.0AMP  
 Contact Resistance: 10mΩ Max  
 Withstand Voltage: 1500V AC/DC  
 Insulation Resistance: 1000MΩ Min  
 Operation Temperature: -40°C to +105°C  
 Contact Material: Brass  
 Contact plating: Matte Sn over Ni  
 Insulator Material: PBT+30%G.F UL94V-0

## Ordering Information

WF2512-WR XX G A X  
 No. of pins: 02~20P  
 Color: G-Grey  
 Packing: A=Tray  
 SERIES: 3=TYPE 1, 5=TYPE 2

Recommended P.C.B Layout (Top Side)  
 (PCB BOARD TOLERANCE±0.05)

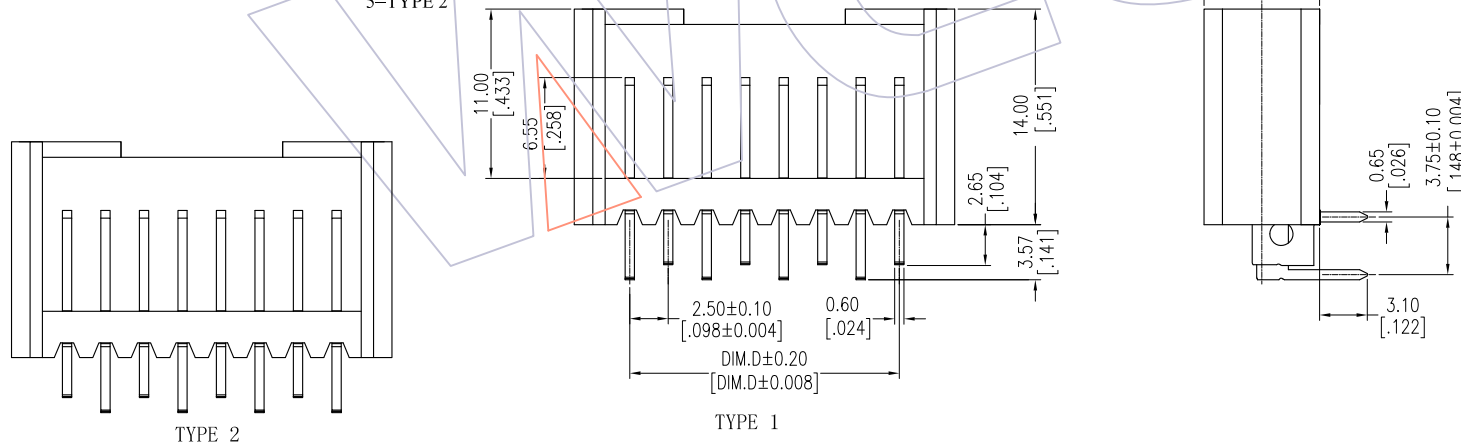
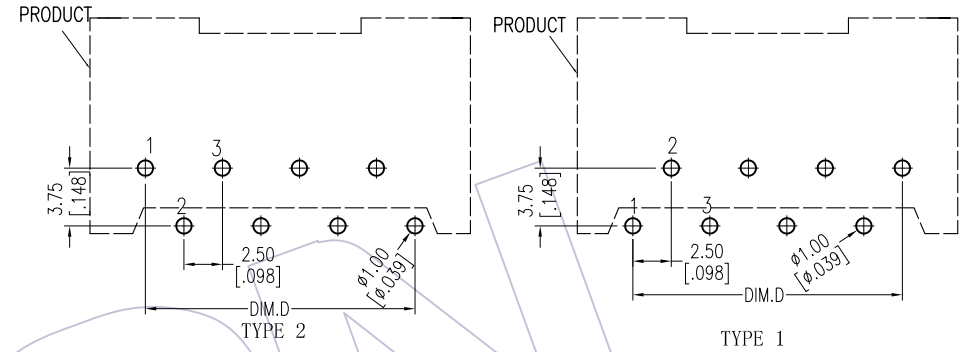
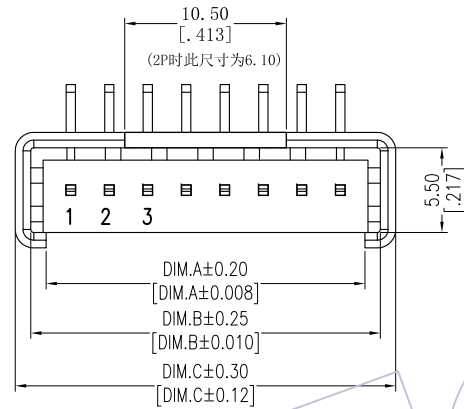

PIN	DIM.A	DIM.B	DIM.C	DIM.D
2P	5.70	7.70	9.70	2.50
3P	8.20	10.20	12.20	5.00
4P	10.70	12.70	14.70	7.50
5P	13.20	15.20	17.20	10.00
6P	15.70	17.70	19.70	12.50
7P	18.20	20.20	22.20	15.00
8P	20.70	22.70	24.70	17.50
9P	23.20	25.20	27.20	20.00
10P	25.70	27.70	29.70	22.50
11P	28.20	30.20	32.20	25.00
12P	30.70	32.70	34.70	27.50
13P	33.20	35.20	37.20	30.00
14P	35.70	37.70	39.70	32.50
15P	38.20	40.20	42.20	35.00
16P	40.70	42.70	44.70	37.50
17P	43.20	45.20	47.20	40.00
18P	45.70	47.70	49.70	42.50
19P	48.20	50.20	52.20	45.00
20P	50.70	52.70	54.70	47.50

REV	DATE	MODIFICATION DESCRIPTION	CHANGE	OPERATION	DRAW	DATE	SCALE	FIT	PART NO.
A2	2017/03/24	Modify PART NO.	△	x.X ±0.40	Ding	2017/03/24	UNIT	mm	WF2512-WRXXGA3 (05) △
A1	2016/06/06	Modify	---	x.XX ±0.25	CHECK	DATE	SIZE	A4	TITLE:
AO	2014/11/10	NEW	---	x.XXX ±0.15	APPROVE	DATE	SHEET	1/1	2.50mm Pitch Wafer 90° Without Latch 错位正向
				Angle ± 3'			PROJ.	Customer NO.	
				DIM TOL					

**WCON**  
 Http: www.wcon.com

WCON-Dongguan  
 Tel: +86 769 85358920  
 Fax: +86 769 85358915  
 E-mail: sales@wcon.com

WCON-Kunshan  
 Tel: +86 512 57468408  
 Fax: +86 512 57468468  
 E-mail: salesks@wcon.com