

HSP

NOTES:
 Rated Current: 5.0AMP
 Contact Resistance: 20mΩ max
 Withstand Voltage: 1000V AC/DC
 Insulation Resistance: 1000MΩ min
 Operation Temperature: -25°C to +85°C

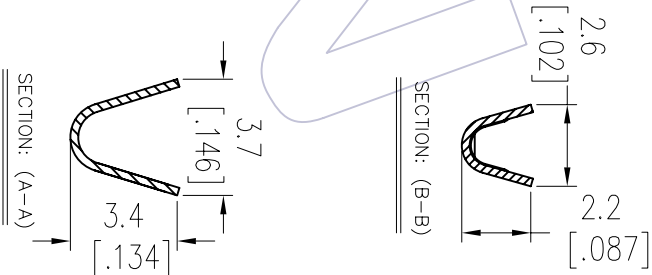
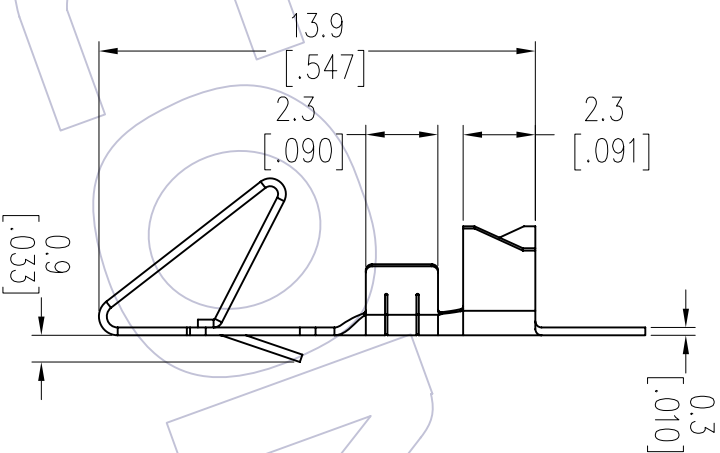
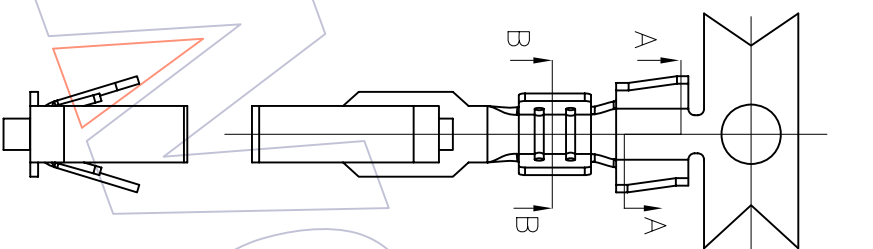

Ordering Information

WF3961 - T X XX 01

Material: Contact Plating:
 B=Brass G0=Gold Flash
 P=Phosphor bronze G3=10μ Gold
 G4=15μ Gold G5=30μ Gold
 S0=Gold Flash/Tin
 S3=10μ Gold/Tin
 S4=15μ Gold/Tin
 S5=30μ Gold/Tin
 SN=Tin

Specification & Ordering Information:

Part No.	Thickness	Finish	Wire Range	Insulation O.D
WF 3961 - TXG001	0.30	Phosphor bronze/Brass	AWG#18~#22	2.80mm(Max)
WF 3961 - TXSN01	0.30	Phosphor bronze/Brass	Tin-Plated	2.80mm(Max)

OPERATION	±0.40
CHECK	±0.25
ANGLE	±0.15
DIM	± 3°

DRAW	JYHuang	DATE	2012/09/11
CHECK		DATE	

SCALE	FIT
UNIT	mm
SIZE	A4
SHEET	1/1

PART NO.	SEE TAB
TITLE:	"M"TYPE 3.96 TERMINAL
CUSTOMER NO.	

WCON
 Http: www.wcon.com

WCON-Dongguan Tel: +86 769 85358920
 WCON-Kunshan Tel: +86 512 57468408
 Fax: +86 769 85358915 Fax: +86 512 57468468
 E-mail: sales@wcon.com E-mail: sales@wcon.com

REV	DATE	MODIFICATION DESCRIPTION	CHANGE
AO	2012/09/11	NEW	

1 2 3 4 5 6 7 8 9 10