

HSF

Recommended P.C.B Layout(Top Side)
(PCB BOARD TOLERANCE±0.05)

NOTES:
Current Rating:7.0AMP
Contact Resistance:20mΩ Max
Withstand Voltage:1000V AC/DC
Insulation Resistance:1000MΩ Min
Operation Temperature:-40℃ to +105℃

Contact Material:Brass
Contact plating:Au Or Sn Over Ni
Insulator Material:PA66 Or PA46 UL94V-0

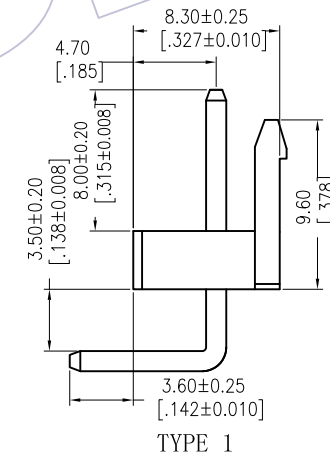
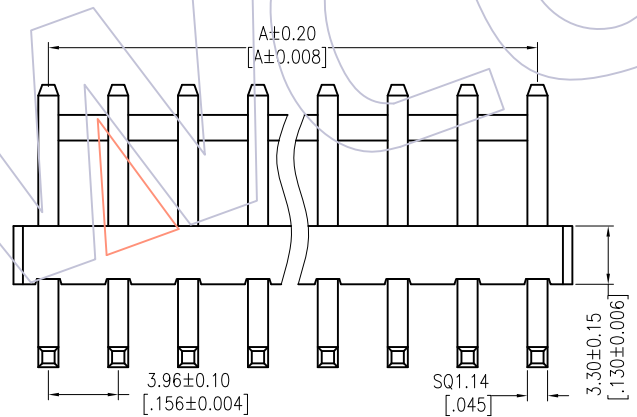
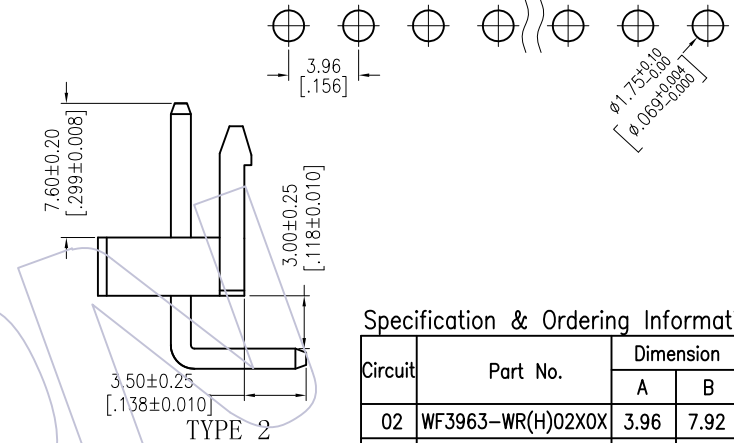
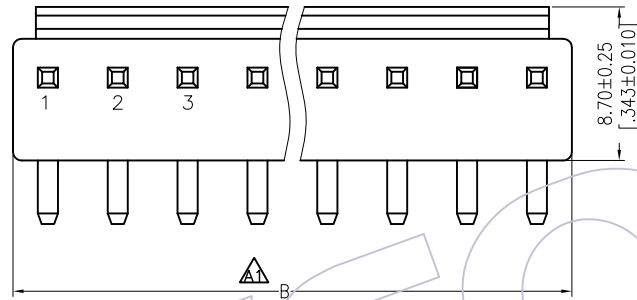

Specification & Ordering Information:

Circuit	Part No.	Dimension		Q'ty /Bag
		A	B	
02	WF3963-WR(H)02X0X	3.96	7.92	700
03	WF3963-WR(H)03X0X	7.92	11.88	600
04	WF3963-WR(H)04X0X	11.88	15.84	450
05	WF3963-WR(H)05X0X	15.84	19.80	350
06	WF3963-WR(H)06X0X	19.80	23.76	300
07	WF3963-WR(H)07X0X	23.76	27.72	250
08	WF3963-WR(H)08X0X	27.72	31.68	200
09	WF3963-WR(H)09X0X	31.68	35.64	180
10	WF3963-WR(H)10X0X	35.64	39.60	150
11	WF3963-WR(H)11X0X	39.60	43.56	120
12	WF3963-WR(H)12X0X	43.56	47.52	90
13	WF3963-WR(H)13X0X	47.52	51.48	70
14	WF3963-WR(H)14X0X	51.48	55.44	50
15	WF3963-WR(H)15X0X	55.44	59.40	30
16	WF3963-WR(H)16X0X	59.40	63.36	30
17	WF3963-WR(H)17X0X	63.36	67.32	20
18	WF3963-WR(H)18X0X	67.32	71.28	20
19	WF3963-WR(H)19X0X	71.28	75.24	20
20	WF3963-WR(H)20X0X	75.24	79.20	20

Ordering Information

WF3963-WR XX X 0 X

H=PA46
Blank=PA66

No. of pins
02~20P

Contact Plating
S0=Gold Flash/Tin
S3=10u"Gold/Tin
S4=15u"Gold/Tin
S5=30u"Gold/Tin
G0=Gold Flash
G3=10u"Gold
G4=15u"Gold
G5=30u"Gold
Blank=Tin

Color
B=Black
T=Natural
W=White

Series No.
1=Type 1
2=Type 2

Packing
0=PE Bag

PART No.	DIM B TOL
WF3963-WRXXXXXX0X(PA66)	±0.30
WF3963-WSHXXXXXX0X(PA46)	+0.40 -0.30

REV	DATE	MODIFICATION DESCRIPTION	CHANGE	OPERATION		DRAW Lizufeng	DATE 2016/03/31	SCALE	FIT	PART NO. SEE TAB
				X.X	±0.40					
A1	2016/03/31	Add PA46 Material and DIM B TOL	—	X.XX	±0.25	CHECK	DATE	UNIT mm inch	A4	TITLE: VH 3.96 Wafer 90°
AO	2012/09/15	NEW	—	X.XXX	±0.15	APPROVE	DATE	SHEET	1/1	Customer NO.
				Angle	± 3'			PROJ.		

WCON

Http: www.wcon.com

WCON-Dongguan
Tel: +86 769 85358920
Fax: +86 769 85358915
E-mail: sales@wcon.com

WCON-Kunshan
Tel: +86 512 57468408
Fax: +86 512 57468468
E-mail: sales@wcon.com