

# HSF

NOTES:  
 Rated Current:7.0A  
 Contact Resistance:20mΩ max  
 Withstand Voltage:1500V AC/Minute  
 Insulation Resistance:1000MΩ min  
 Operation Temperature:-25℃ to+85℃

Contact Material:Brass  
 Contact plating:Au or Sn over Ni  
 Insulator Material:PA66 UL94-V2

Recommended P.C.B Layout(Top Side)  
 (PCB BOARD TOLERANCE±0.05)

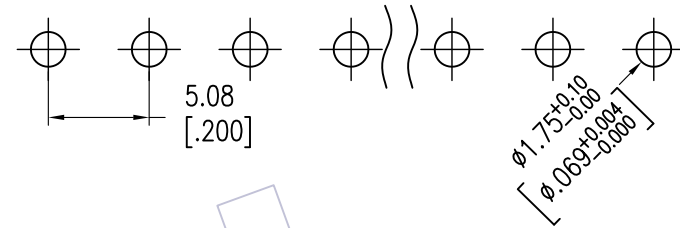

模穴号  
1,2,3...

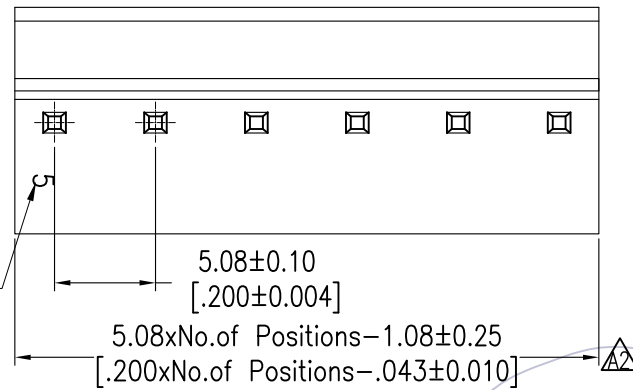

## Ordering Information

WF5081 -WS

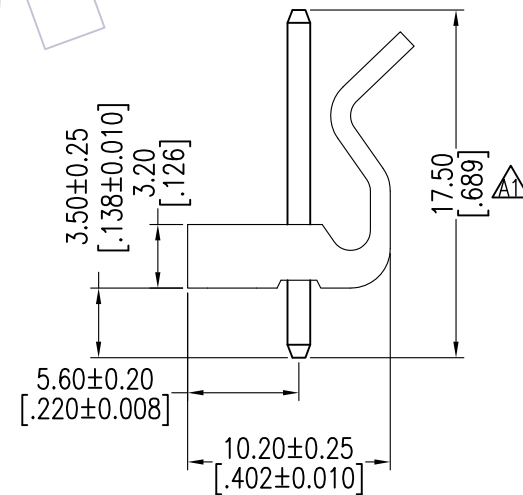
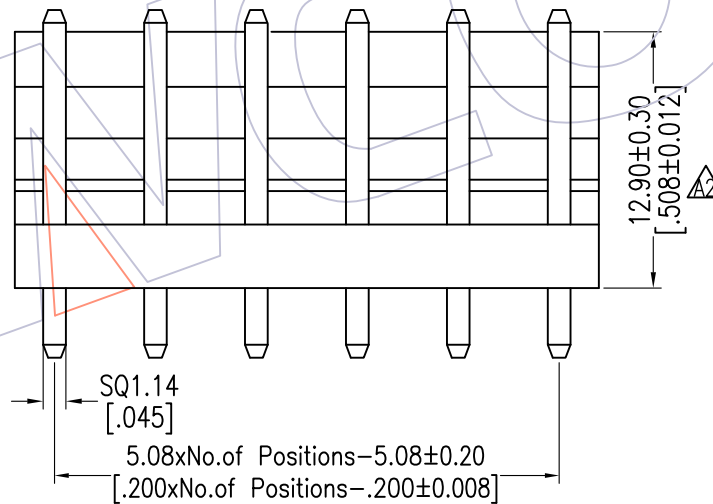
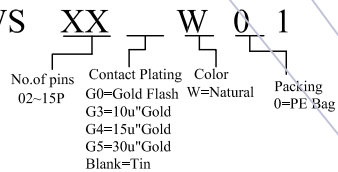

REV	DATE	MODIFICATION DESCRIPTION	CHANGE	OPERATION	DRAW	DATE	SCALE	FIT	PART NO.
A2	2016/12/22	Modify the drawing	△	x.X ±0.40	DingWenMin	2016/12/22	UNIT	mm inch	WF5081-WSXXW01
A1	2013/09/05	16.50--17.50	△	x.XX ±0.25	CHECK	DATE	SIZE	A4	TITLE: 5.08 WAFER 180° DIP
A0	2012/09/17	NEW	—	x.XXX ±0.15	APPROVE	DATE	SHEET	1/1	Customer NO.
				Angle ± 3'			PROJ.		
				DIM TOL					

# WCON

Http: www.wcon.com

WCON-Dongguan Tel: +86 769 85358920 Fax: +86 769 85358915 E-mail: sales@wcon.com  
 WCON-Kunshan Tel: +86 512 57468408 Fax: +86 512 57468468 E-mail: salesks@wcon.com