

HSF

Recommended P.C.B Layout(Top Side)
(PCB BOARD TOLERANCE±0.05)

NOTES:

- Current Rating: 3.0AMP
- Contact Resistance: 20mΩ Max
- Withstand Voltage: 1000V AC/DC
- Insulation Resistance: 1000MΩ Min
- Operation Temperature: -40°C to +105°C
- Contact Material: Phosphor Bronze
- Contact plating: Au Or Sn over Ni
- Insulator Material: PA9T+30%G.F UL94V-0

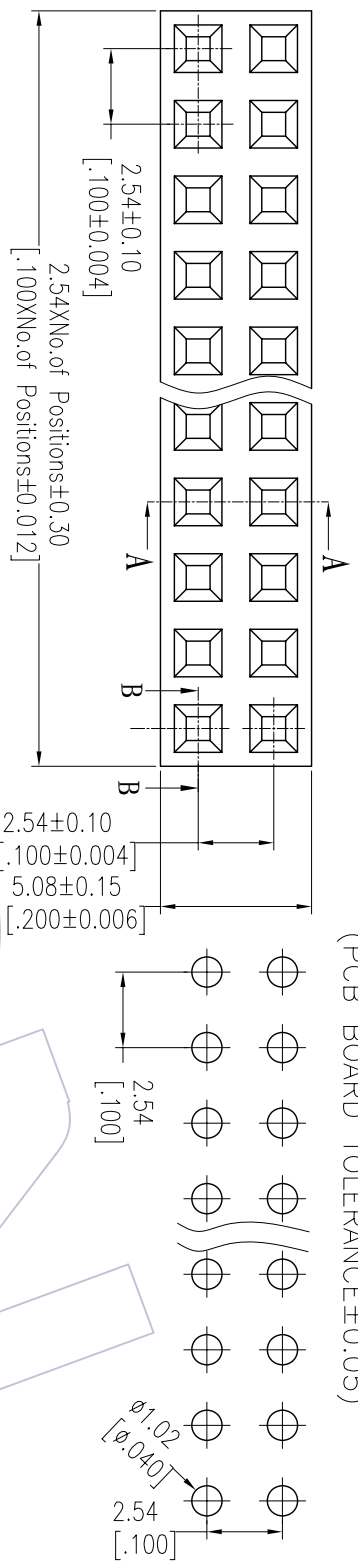

Ordering Information

2135 - 2 XX S XX CUN X 1

- No. of Pins per ROW: 02-40PIN
- Contact Plating: G=Gold Flash, G3=10μ"Gold, G4=15μ"Gold, G5=30μ"Gold, S0=Gold Plastr/Tin, S3=10μ"Gold/Tin, S4=15μ"Gold/Tin, S5=30μ"Gold/Tin, SN=Tin, SNE=Lead Free Tin
- Packing: T=Tube

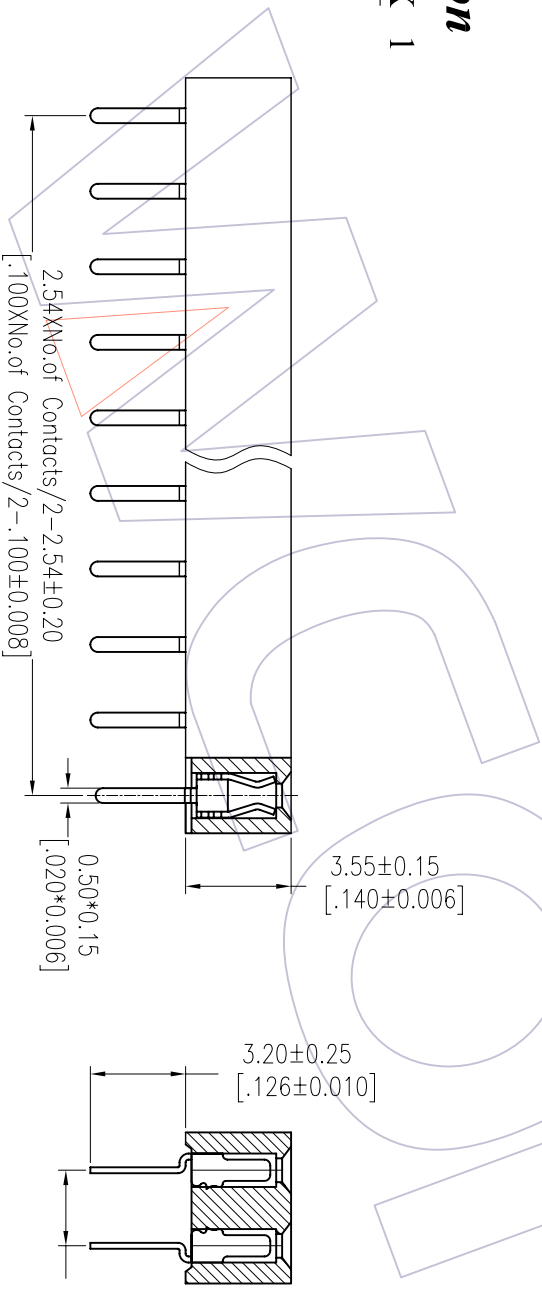

Item	Pitch	Mating
Standard	2.54	1115/1120/1125
Alternate		

OPERATION		DRAW		DATE		SCALE		PART NO.	
XX	±0.40	Wang		2012/12/07		mm		2135-2XXSXXCUNX1	
CHECK		CHECK		DATE		SIZE		TITLE:	
X.XXX	±0.15					A4		FH2.54 DUAL ROW 180° H=3.5	
Angle		APPROVE		DATE		SHEET		Customer NO.	
X.XXX	± 3'					1/1			
DIM		TOL		PROJ.		Customer NO.			
CHANGE		APPROVE		DATE		SHEET		Customer NO.	
MODIFICATION DESCRIPTION		APPROVE		DATE		SHEET		Customer NO.	
NEW									
DATE		DATE		DATE		DATE		DATE	
2012/12/07									
REV		REV		REV		REV		REV	
A0		A0		A0		A0		A0	

WCON

Http: www.wcon.com
 WCON-Dongguan Tel: +86 769 85358920 Fax: +86 769 85358915 E-mail: sales@wcon.com
 WCON-Kunshan Tel: +86 512 57468408 Fax: +86 512 57468468 E-mail: sales@wcon.com