

HSF

TECHNICAL SPECS:

Current Rating: 3.0AMP
 Contact Resistance: 10m Ω Max
 Dielectric Strength: Min 1000Vrms
 Mechanical Life: Min 500 cycles
 Operation Temperature: -40°C to +105°C

Sleeve: Brass CuZn36Pb3(C36000)
 Contact plating: Au over Ni
 Connecting Pin: Ø0.50mm
 Insulator Material: PPS+30%G.F(U94V-0)

Ordering Information

3510-302 XX S XX 137 X 1

No. of Pin
2~50PIN

Contact Plating
G0=Gold Flash
G3=10u"Gold
G4=15u"Gold
G5=30u"Gold

Packing
A=Tray
T=Tube

Item	Pitch	Mating
Standard	2.54	3520
Alternate		

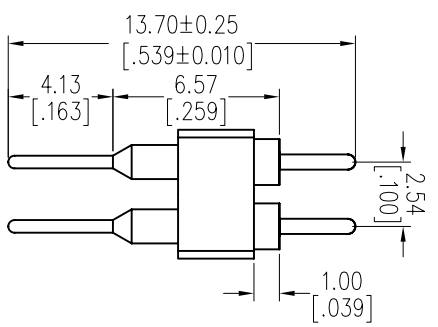
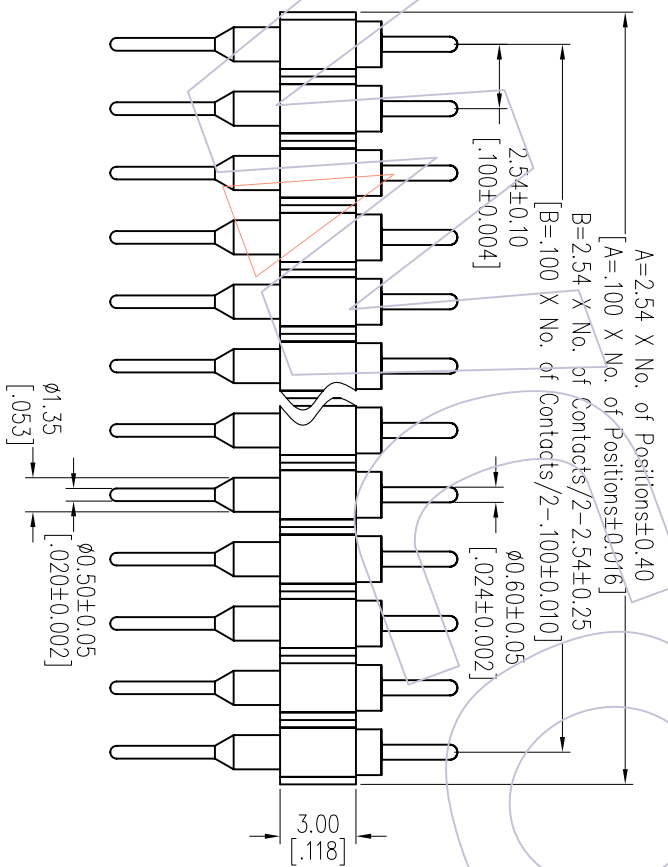
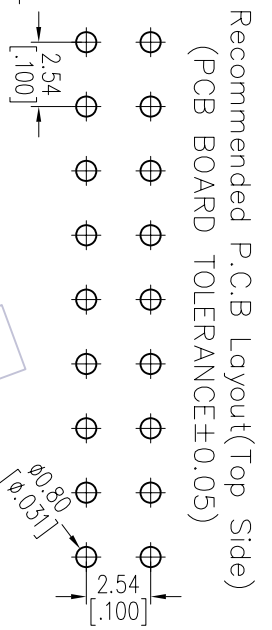
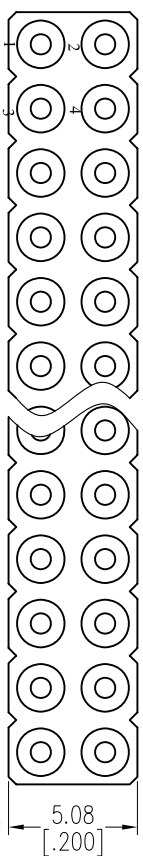

REV	DATE	MODIFICATION DESCRIPTION	CHANGE	OPERATION	DRAW	DATE	SCALE	FIT	PART NO.	TITLE: 2.54mm MACHINED PIN HEADER DUAL ROW 180° H=3.00 L=13.7	Customer NO.	WCON-Dongguan Tel: +86 769 85358920 Fax: +86 769 85358915 E-mail: sales@wcon.com	WCON-Kunshan Tel: +86 512 57468408 Fax: +86 512 57468468 E-mail: sales@wcon.com
A0	2012/10/22	NEW		XX	JYHuang	2012/10/22	mm	A4	3510-302XXSXX137X1				
REV	DATE	MODIFICATION DESCRIPTION	CHANGE	OPERATION	DRAW	DATE	SCALE	FIT	PART NO.				
				XX			±0.40						
				X.XX	CHECK	DATE	±0.25						
				X.XXX		DATE	±0.15						
				Angle	APPROVE	DATE	± 3°						
				DIM	PROJ.								
				TOL									

WCON

Http: www.wcon.com