

HSF

NOTES:
 Current Rating: 3.0AMP
 Contact Resistance: 20mΩ Max
 Withstand Voltage: 1000V AC/DC
 Insulation Resistance: 1000MΩ Min
 Operation Temperature: -40°C to +105°C

Contact Material: Brass
 Contact plating: Au Or Sn over Ni
 Insulator Material: PA9T+33%G.F UL94V-0(Std)

Recommended P.C.B Layout(Top Side)
 (PCB BOARD TOLERANCE±0.05)

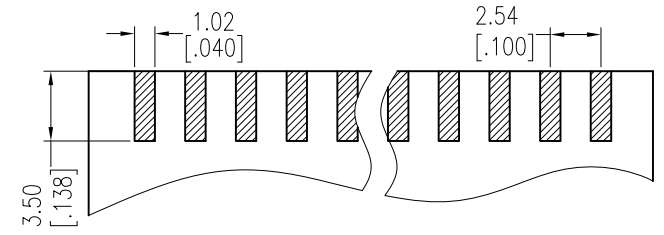
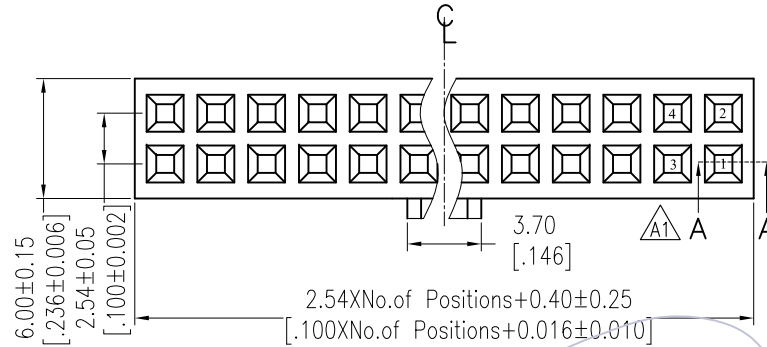

Ordering Information

2185 - 2 XX C XX X Y N X X

No. of Pins per ROW: 02-40PIN
 Contact Plating:
 G0=Gold Flash
 G3=10μ"Gold
 G4=15μ"Gold
 G5=30μ"Gold
 S0=Gold Flash/Tin
 S3=10μ"Gold/Tin
 S4=15μ"Gold/Tin
 S5=30μ"Gold/Tin
 SN=Tin
 SM=Matte Tin
 Insulator : C=PA9T
 Packing: T=Tube
 Series No.: 1=TYPE 1
 2=TYPE 2

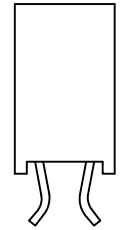
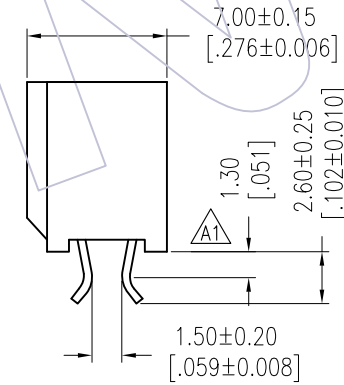
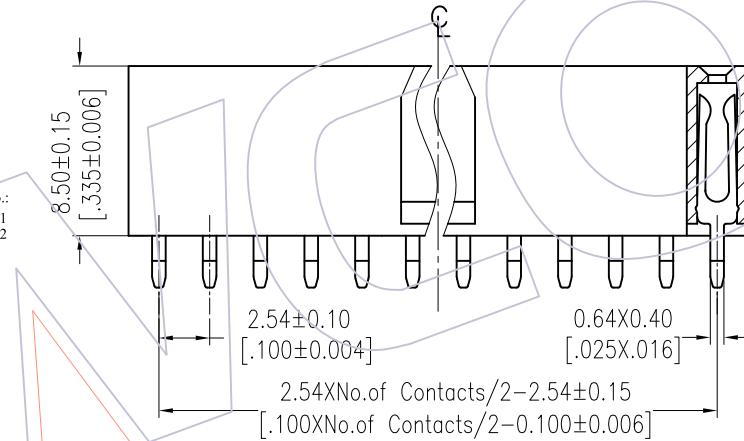

TYPE1: WITH BUMP

TYPE2: W/O BUMP

Item	Pitch	Mating
Standard	2.54	1115/1120/1125
Alternate		

REV	DATE	MODIFICATION DESCRIPTION	CHANGE	OPERATION	DRAW	DATE	SCALE	FIT	PART NO.
A2	2017/07/12	Modify drawing	-----	x.x ±0.40	Surong Xu	2017/07/12	UNIT mm		2185-2XXCXXXYNXX
A1	2013/04/14	Modify drawing	-----	x.xx ±0.25	CHECK	DATE	SIZE A4		TITLE: FH2.54 DUAL ROW SPLINT H=8.50
A0	2012/08/15	NEW	-----	x.xxx ±0.15	APPROVE	DATE	SHEET 1/1		Customer NO.
				Angle ± 3'			PROJ.		
				DIM TOL					

WCON

Http: www.wcon.com

WCON-Dongguan Tel: +86 769 85358920 Fax: +86 769 85358915 E-mail: sales@wcon.com
 WCON-Kunshan Tel: +86 512 57468408 Fax: +86 512 57468468 E-mail: salesks@wcon.com