

# HSF

NOTES:  
 Current Rating: 7.0AMP  
 Contact Resistance: 30mΩ Max  
 Withstand Voltage: 1000V AC/DC  
 Insulation Resistance: 1000MΩ Min  
 Operation Temperature: -40°C to +105°C

Contact Material: Phosphor Bronze  
 Contact plating: Sn over Ni  
 Insulator Material: LCP+30%G.F UL94V-0

Recommended P.C.B Layout (Top Side)  
 (PCB BOARD TOLERANCE ±0.05)

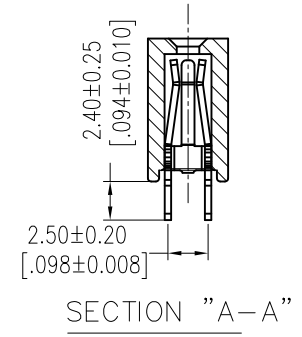
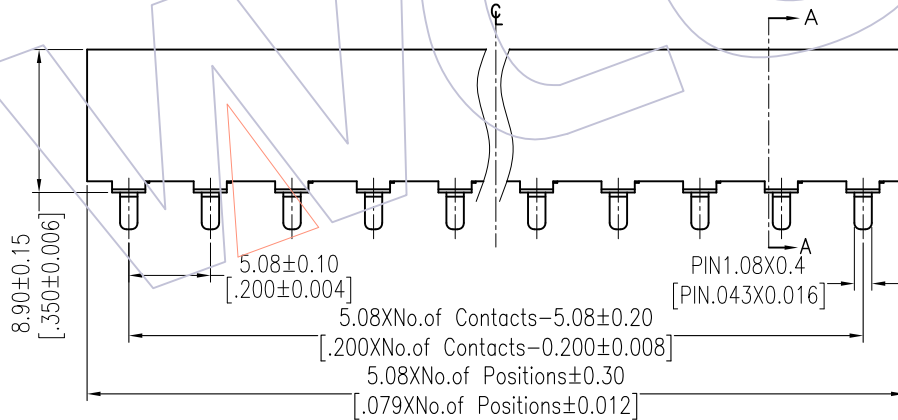
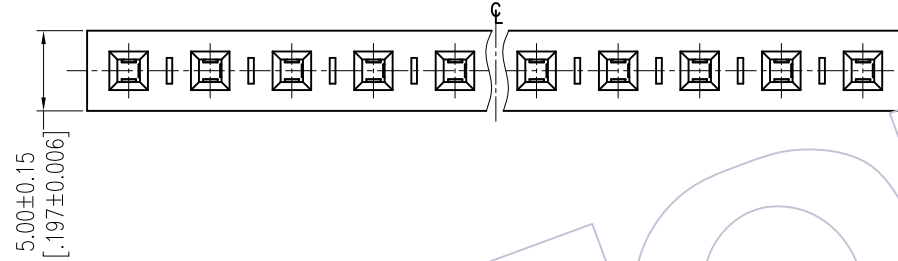
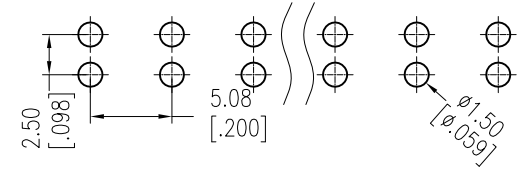

## Ordering Information

2989 - 1 XX S XX DUNT 1

No. of Pins per ROW: 02-20PIN  
 A1

Contact Plating:  
 SN=Tin  
 SM=Matte Tin

Packing:  
 T=Tube

Item	Pitch	Mating
Standard	5.08	1925
Alternate		

REV	DATE	MODIFICATION DESCRIPTION	CHANGE	OPERATION	DRAW	DATE	SCALE	FIT	PART NO.
A1	2017/06/08	MODIFY	-----	x.x ±0.40	Surong Xu	2017/06/08	UNIT	mm	2989-1XXSXXDUNT1
AO	2012/08/15	NEW	-----	x.xx ±0.25	CHECK	DATE	SIZE	A4	TITLE: FH5.08 SINGLE ROW 180°DIP H=8.9
				x.xxx ±0.15	APPROVE	DATE	SHEET	1/1	Customer NO.
				Angle ± 3'			PROJ.		
				DIM TOL					

# WCON

Http: www.wcon.com

WCON-Dongguan  
 Tel: +86 769 85358920  
 Fax: +86 769 85358915  
 E-mail: sales@wcon.com

WCON-Kunshan  
 Tel: +86 512 57468408  
 Fax: +86 512 57468468  
 E-mail: salesks@wcon.com