

HSF

UL&CSA GRADE:

UL Style.....2651
 Rate Temperature.....-20°C TO 105°C
 Rate Voltage.....Max 300V
 Flame Test.....VW-1

CSA Standard.....C22.2 NO.210.2
 Rate Temperature.....-20°C TO 105°C
 Rate Voltage.....Max 300V
 Flame Test.....FT1.FT2

Physical Property:

Stranded Conductor
 AWG Size.....28AWG
 Material of Insulation.....Polyvinyl Chloride(PVC)
 Insulation thickness average.....9 mil
 Min Insulation Thickness.....7 mil

Electronic Characteristics:

Spark test.....2500V
 Dielectric strength test.....Min 2KV in 1 minute
 Conductor resistance.....Max 237Ω/km
 Insulation resistance.....Min 100MΩ-km
 Capacity.....44PF/m(G-S-G)
 Inductance.....1.45 μH/m
 Impedance.....105Ω(G-S-G)
 Propagation delay time.....4.2 ns/m

Ordering Information

F1U-C 28 G XX D 0 -XXXX- X

PITCH
1.27

No. of Pins
04-64P

Flat Cable Length

Journal
Number

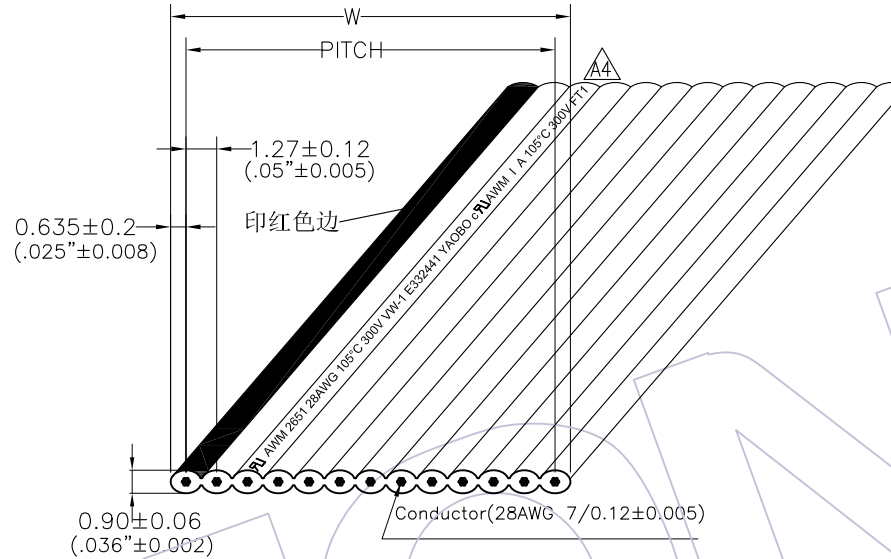

印字: AWM 2651 28AWG 105°C 300V VW-1 E332441 YAobo c AWM A 105°C 300V FT1
 字体印在第三与第四PIN之间.

NUMBER OF CORES	WIDTH(mm)	Pitch(mm)	Allowable ERROR(mm)
2	2.54	1.27	±0.10
4	5.08	3.81	±0.15
5	6.35	5.08	±0.15
6	7.62	6.35	±0.15
7	8.89	7.62	±0.15
8	10.16	8.89	±0.15
9	11.43	10.16	±0.15
10	12.70	11.43	±0.15
12	15.24	13.97	±0.15
14	17.78	16.51	±0.15
15	19.05	17.78	±0.15
16	20.32	19.05	±0.15
18	22.86	21.59	±0.15

NUMBER OF CORES	WIDTH(mm)	Pitch(mm)	Allowable ERROR(mm)
20	25.40	24.13	±0.15
25	31.75	30.48	±0.20
26	33.02	31.75	±0.20
28	35.56	34.29	±0.20
30	38.10	36.83	±0.20
34	43.18	41.91	±0.20
36	45.72	44.45	±0.20
37	46.99	45.72	±0.20
40	50.80	49.53	±0.20
50	63.50	62.23	±0.20
60	76.20	74.93	±0.20
64	81.28	80.01	±0.20

REV	DATE	MODIFICATION DESCRIPTION	CHANGE	DIM	TOL	OPERATION	SCALE	FIT	PART NO.
A4	2017/05/02	修改印字内容	—			OPERATION	SCALE	FIT	PART NO.
A3	2014/11/05	修改印字内容	—	X.X	±0.40	OPERATION	UNIT	mm	F1U-C28GXXD0-XXXX-X
A2	2013/07/12	增加耀博印字内容	—	X.XX	±0.25	CHECK	SIZE	A4	TITLE:
A0	2010/02/05	NEW	—	X.XXX	±0.15	CHECK	SHEET	1/1	UL2651 1.27mm 28AWG Flat Cable
				Angle	± 3'	APPROVE	PROJ.		Customer NO.



Http: www.wcon.com

WCON-Dongguan
 Tel: +86 769 85358920
 Fax: +86 769 85358915
 E-mail: sales@wcon.com

WCON-Kunshan
 Tel: +86 512 57468408
 Fax: +86 512 57468468
 E-mail: salesks@wcon.com