

# HSF

IDC HOUSING MATERIAL  
 Insulation Material:PBT+30%GF(UL94V-0)  
 Contact Material:Phosphor Bronze  
 Contact plating:Au or Sn Over Ni

SPECIFICATIONS  
 Insulation Resistance:5MΩ Min  
 Contact Resistance:1.0Ω Max  
 Withstand Voltage:DC 300V, 10S  
 The Cable Assembly Must 100% Test

CABLE MATERIAL  
 Insulation:UL 2678,Grey Red Side  
 Conductor:30AWG(7/0.102mm)  
 Electrical:300V

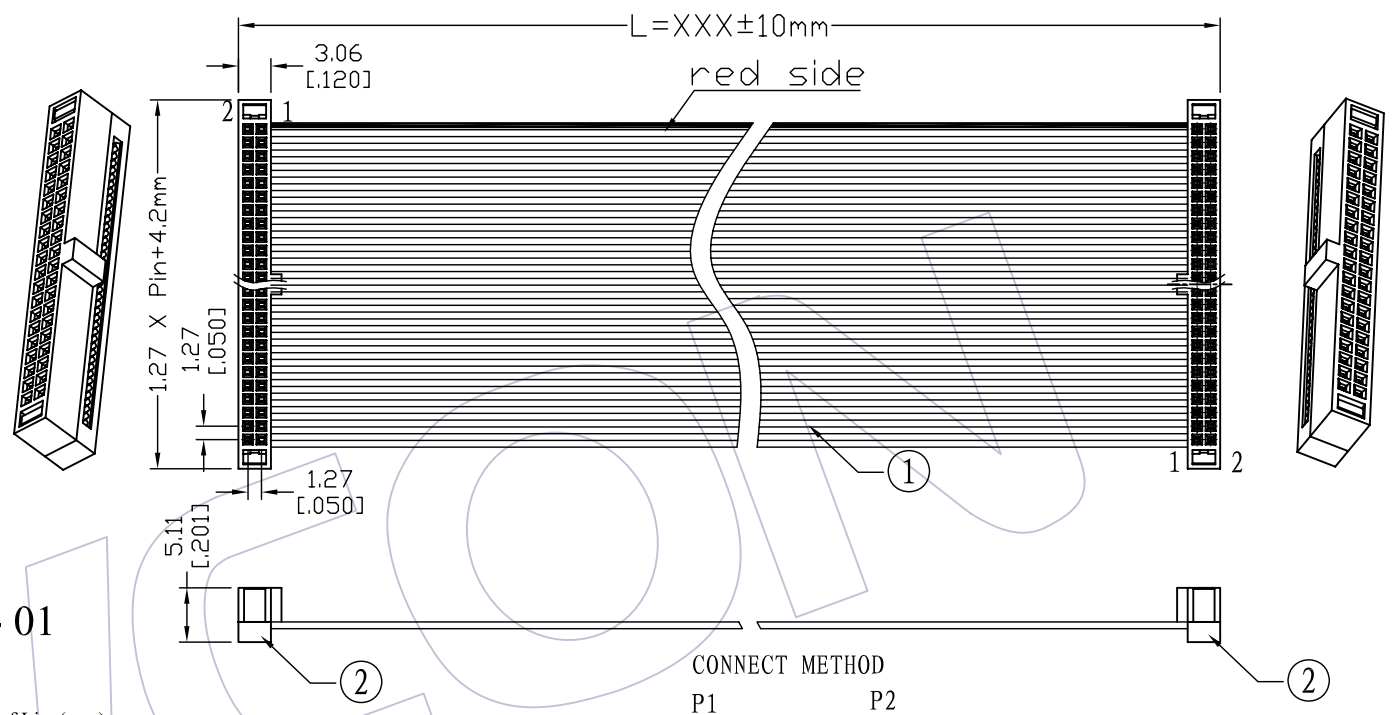

## Ordering Information

FA32 - xx xx A B B xxx - 01

No. OF Pins: 06~100p  
 Contact Plating:  
 G0=Gold Flash  
 G3=10u"Gold  
 G4=15u"Gold  
 G5=30u"Gold  
 S0=Gold Flash/Ni  
 S3=10u"Gold/Ni  
 S4=15u"Gold/Ni  
 S5=30u"Gold/Ni  
 SN=Tin

Connector Color:  
 B=Black

Connector Direction:  
 A=Same Direction

Length of Line(mm)

### CONNECT METHOD

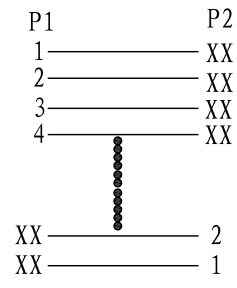

②	5232-XXUPXXBW01	CONN.	1.27 IDC **P PBT Black With Bump Phosphor Bronze Plating Xu" gold	2	SET
①	F3U-A30GXXD0-XXXX-1	WIRE	UL2678 PH0.635mm XXP 30AWG (7/0.102TC) PVC Grey Marking Red Side	XXXX	MM
NO.	PART NO.	NAME	TITLE	QT'Y	UNIT

					OPERATION	DRAW	BEN	09/06/25	SCALE	1:1	<b>WCON</b> 维峰五金电子有限公司 WAFE HARDWARE ELECTRONICS CO. LTD		
					X.X ±0.40	DESIGN			UNIT	mm			
					X.XX ±0.25	CHECK			SIZE	A4		PART NO.	FA32 -xxxxABBxxx-01
					X.XXX ±0.15	APPROVE			SHEET	1/1		TITLE:	1.27 IDC Drawing
AO	09/06/25	NEW			Angle ± 3'				PROJ.	☞	Customer NO.		
REV	DATE	MODIFICATION DESCRIPTION	CHANGE	APPROVE	DIM TOL	APPROVE							