

HSF

IDC HOUSING MATERIAL
 Insulation Material:PBT+30%GF(UL94V-0)
 Contact Material:Phosphor Bronze
 Contact plating:Au or Sn Over Ni

SPECIFICATIONS

Insulation Resistance:5MΩ Min
 Contact Resistance:1.0Ω Max
 Withstand Voltage:DC 300V, 10S
 The Cable Assembly Must 100% Test

CABLE MATERIAL

Insulation:UL 2678, Grey Red Side
 Conductor:30AWG(7/0.102mm)
 Electrical:300V

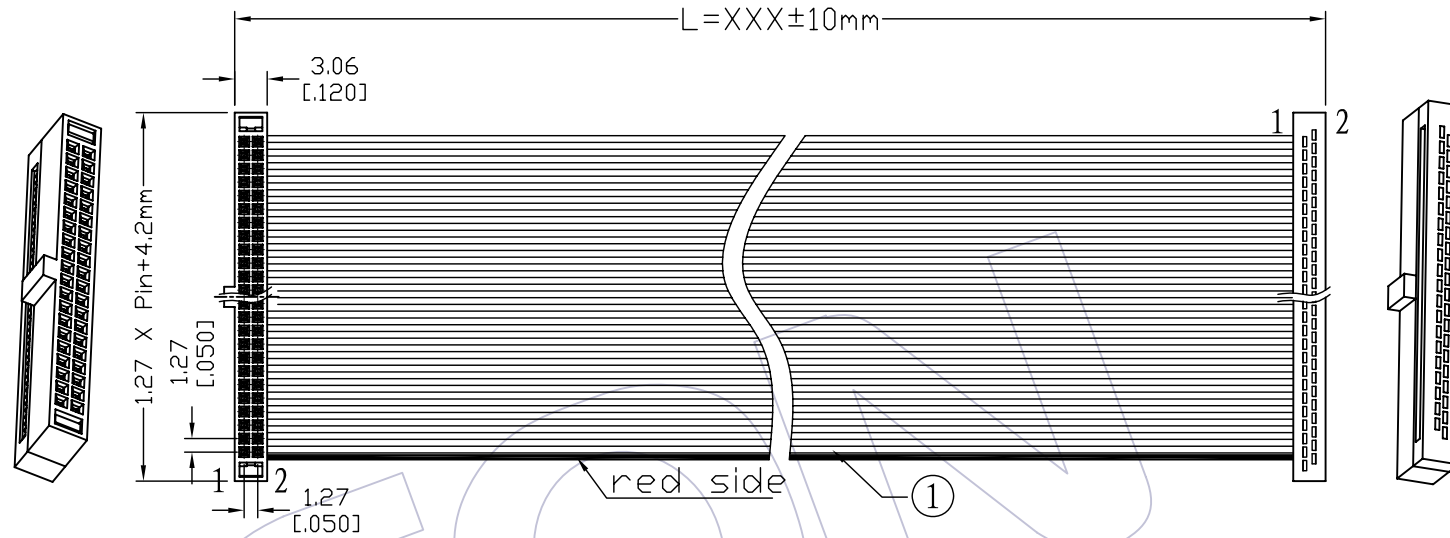

Ordering Information

FA32 - xx xx B B B xxx - 01

No. OF Pins: 06-100p
 Contact Plating:
 G0=Gold Flash
 G3=10u"Gold
 G4=15u"Gold
 G5=30u"Gold
 S0=Gold Flash/Ni
 S3=10u"Gold/Ni
 S4=15u"Gold/Ni
 S5=30u"Gold/Ni
 SN=Tin
 Connector Direction:
 B=Opposite Direction
 Connector Color:
 B=Black
 Length of Line(mm)

CONNECT METHOD

P1	P2
1	XX
2	XX
3	XX
4	XX
XX	2
XX	1

②	5232-XXUPXXBW01	CONN.	1.27 IDC **P PBT Black With Bump Phosphor Bronze Plating Xu" gold	2	SET
①	F3U-A30GXXD0-XXXX-1	WIRE	UL2678 PH0.635mm XXP 30AWG (7/0.102TC) PVC Grey Marking Red Side	XXXX	MM
NO.	PART NO.	NAME	TITLE	QT'Y	UNIT

					OPERATION	DRAW	BEN	09/06/25	SCALE	1:1	WCON 维峰五金电子有限公司 WAFE HARDWARE ELECTRONICS CO. LTD		
					x.x ±0.40	DESIGN			UNIT	mm			
					x.xx ±0.25	CHECK			SIZE	A4		PART NO.	FA32 -xxxxBBBxxx- 01
					x.xxx ±0.15	APPROVE			SHEET	1/1		TITLE:	1.27 IDC Drawing
AO	09/06/25		NEW		Angle ± 3'				PROJ.	Customer NO.			
REV	DATE	MODIFICATION	DESCRIPTION	CHANGE	APPROVE	OPERATION	NAME	DATE	SCALE	UNIT	PART NO.	TITLE	