

HSF

IDC HOUSING MATERIAL

Insulation Material:PBT+30%GF(UL94V-0)

Contact Material:Phosphor Bronze

Contact plating:Au or Sn Over Ni

SPECIFICATIONS

Insulation Resistance:5MΩ Min

Contact Resistance:1.0Ω Max

Withstand Voltage:DC 300V, 10S

The Cable Assembly Must 100% Test

CABLE MATERIAL

Insulation:UL 2651,Grey Red Side

Conductor:28AWG(7/0.12mm)

Electrical:300V

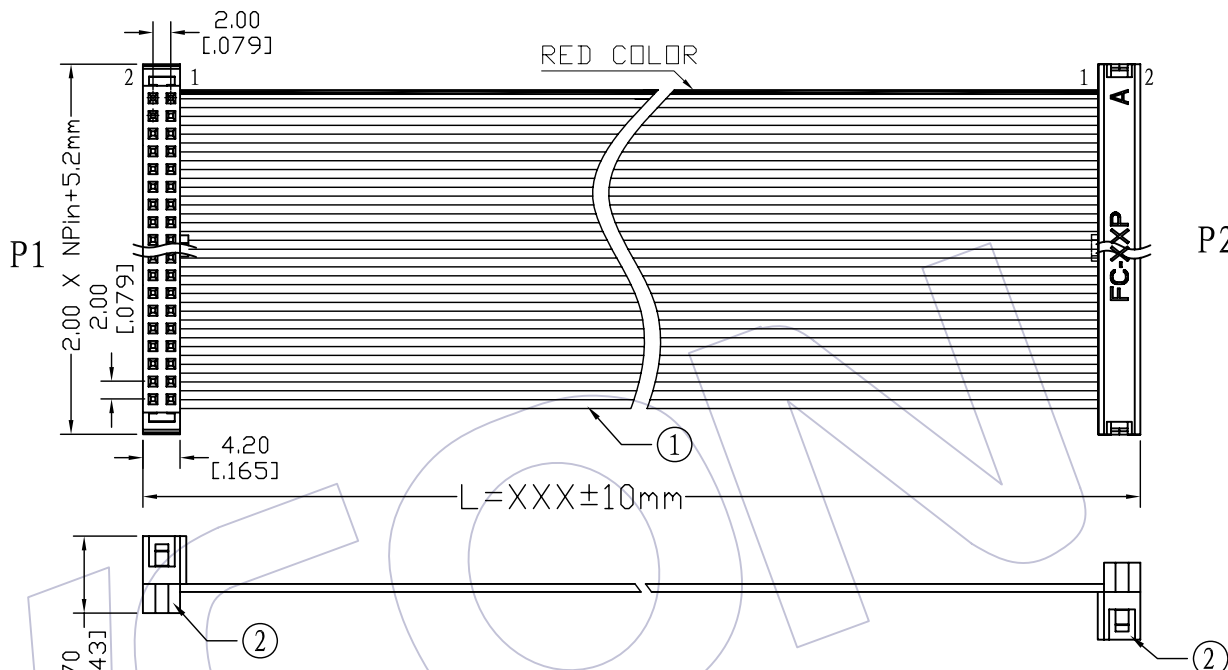

Ordering Information

FA22 - xx xx B A B xxx - 01

No.OF Pins
06~64p

Contact Plating:
G0=Gold Flash
G3=10u"Gold
G4=15u"Gold
G5=30u"Gold
S0=Gold Flash/Ni
S3=10u"Gold/Ni
S4=15u"Gold/Ni
S5=30u"Gold/Ni
SN=Tin

Connector Direction:
B=OPPOSITE Direction

Connector Color:
B=Black

Length of Line(mm)

CONNECT METHOD

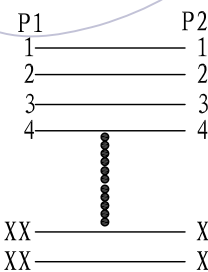

| ② | 5222-XXYPXXBW01 | CONN. | 2.00 IDC **P PBT Black Phosphor Bronze Plating Xu" gold With Bump | 2 | SET |
|-----|---------------------|-------|---|------|------|
| ① | F1U-B28GXXD0-XXXX-1 | WIRE | UL2651 PH1.0mm XXP 28AWG (7/0.12TC) PVC Grey Marking Red Side | XXXX | MM |
| NO. | PART NO. | NAME | TITLE | QT'Y | UNIT |

| | | | | | | OPERATION | DRAW | BEN | 09/08/20 | SCALE | 1:1 | WCON 维峰五金电子有限公司 WAFE HARDWARE ELECTRONICS CO. LTD | | |
|-----|----------|--------------|-------------|--------|---------|-------------|---------|-----|----------|-------|-----|---|----------|----------------------|
| | | | | | | x.x ±0.40 | DESIGN | | | UNIT | mm | | | |
| | | | | | | x.xx ±0.25 | CHECK | | | SIZE | A4 | | PART NO. | FA22 -xxxxBABxxx- 01 |
| | | | | | | x.xxx ±0.15 | APPROVE | | | SHEET | 1/1 | | TITLE: | 2.00 IDC Drawing |
| AO | 09/08/20 | | NEW | | | Angle ± 3' | | | | PROJ. | ☉ | Customer NO. | | |
| REV | DATE | MODIFICATION | DESCRIPTION | CHANGE | APPROVE | DIM TOL | | | | | | | | |