

# HSF

**NOTES:**

1. ELECTRICAL:
  - 1.1 CONTACT CURRENT RATING: 5 AMPERES
  - 1.2 CONTACT RESISTANCE: 10 MILLIOHMS MAX.
  - 1.3 DIELECTRIC WITHSTANDING VOLTAGE: 800V AC FOR 1MINUTE
  - 1.4 INSULATION RESISTANCE: 5000 MEGOHMS MIN AT 500V DC
2. MECHANICAL:
  - 2.1 SCREW COUNTER TORSION FORCE: 10.5 KgF.cm MIN.
  - 2.2 MATING LIFE: 500 cycles.
3. ENVIRONMENTAL:
  - 3.1 TEMPERATURE RATING: -40°C TO +85°C.
  - 3.2 WATERPROOF CLASS: IP67
  - 3.3 AIRPROOF CAPABILITY: PRESSURE DROP 0.3 KPa MAX.
4. WIRE RANGE: 20#~24# AT 52.2 KPa FOR 3 MINUTE.
5. ALL MATERIALS SHOULD BE COMPLIANT TO ROHS

## Ordering Information

6241-09 M L XX X B X 1

No. of Pins 09	Contact Plating G0=Gold Flash G3=10u"Gold G4=12u"Gold G5=30u"Gold	Waterproof Circle F=With Front Waterproof Circle B=With Back Waterproof Circle	Color B=Black	N=Without Cap W=With Cap
-------------------	---	--	------------------	-----------------------------

FACE PLATE HOLE THICKNESS 1.00~1.50mm SCALE 1:2

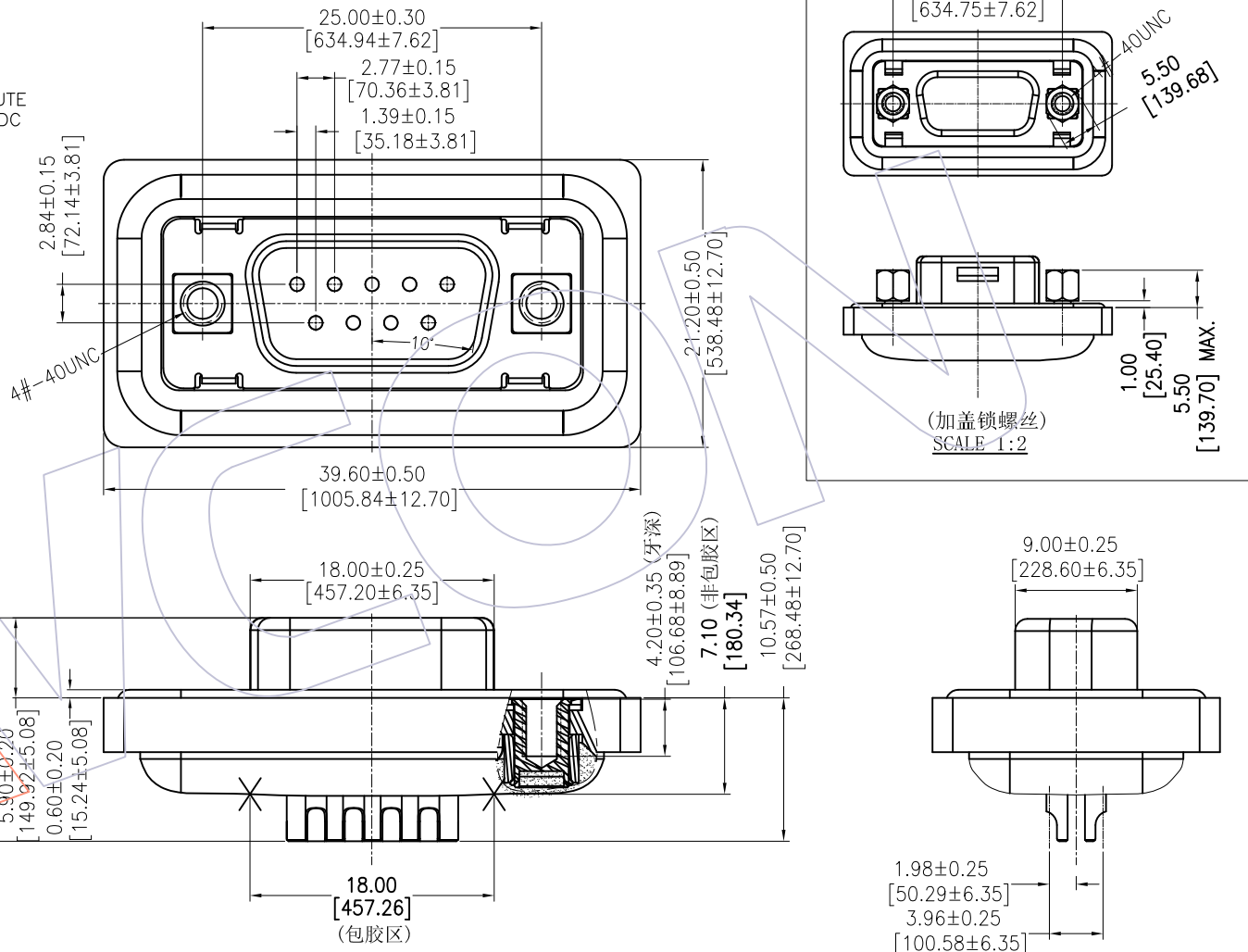

REV	DATE	MODIFICATION DESCRIPTION	CHANGE	OPERATION		DRAW	DATE	SCALE	FIT	PART NO.
				X.X	±0.40					
				X.XX	±0.25	DingWenMin	2016/11/01		mm	6241-09MLXXFBX1
				X.XXX	±0.15	CHECK	DATE		inch	TITLE:
				Angle	± 3'	APPROVE	DATE		A4	D-SUB 9P MALE DOUBLE ROWS
				DIM	TOL				1/1	180° SOLDER TYPE WITH WATERPROFF
									PROJ.	Customer NO.

# WCON

Http: www.wcon.com

WCON-Dongguan Tel: +86 769 85358920 Fax: +86 769 85358915 E-mail: sales@wcon.com	WCON-Kunshan Tel: +86 512 57468408 Fax: +86 512 57468468 E-mail: salesks@wcon.com
---	--