

HSF

NOTES:

1. ELECTRICAL:
 - 1.1 CONTACT CURRENT RATING: 3 AMPERES
 - 1.2 CONTACT RESISTANCE: 35 MILLIOHMS MAX.(UPPER)
25 MILLIOHMS MAX.(LOWER)
 - 1.3 DIELECTRIC WITHSTANDING VOLTAGE: 800V AC FOR 1MINUTE
 - 1.4 INSULATION RESISTANCE: 5000 MEGOHMS MIN AT 500V DC
2. MECHANICAL:
 - 2.1 SCREW COUNTER TORSION FORCE: 10.5 KgF.cm MIN.
 - 2.2 MATING LIFE: 500 CYCLES.
3. ENVIRONMENTAL:
 - 3.1 TEMPERATURE RATING: -40°C TO +85°C.
 - 3.2 WATERPROOF CLASS: IP67
 - 3.3 AIRPROOF CAPABILITY: PRESSURE DROP 0.3 KPa MAX.
4. WIRE RANGE: 20#~24# AT 52.2 KPa FOR 3 MINUTE.
5. ALL MATERIALS SHOULD BE COMPLIANT TO ROHS

Ordering Information

6244-15 M L XX X B X 1

No. of Pins	Contact Plating	Waterproof Circle	Color	N=Without Cap
15	G0=Gold Flash G3=10u"Gold G4=12u"Gold G5=30u"Gold	F=With Front Waterproof Circle B=With Back Waterproof Circle	B=Black	W=With Cap

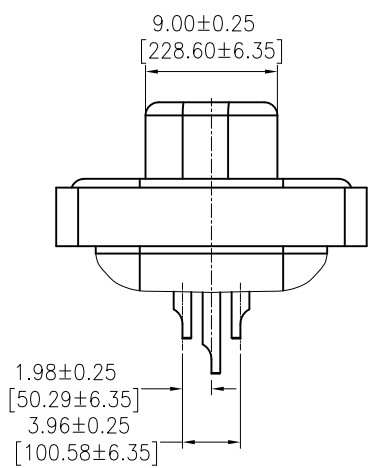
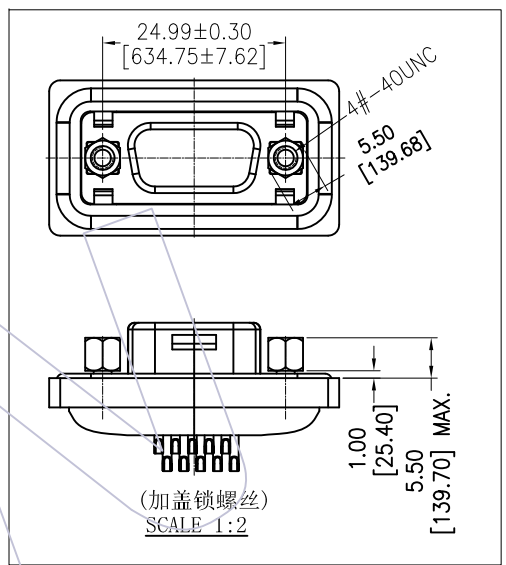
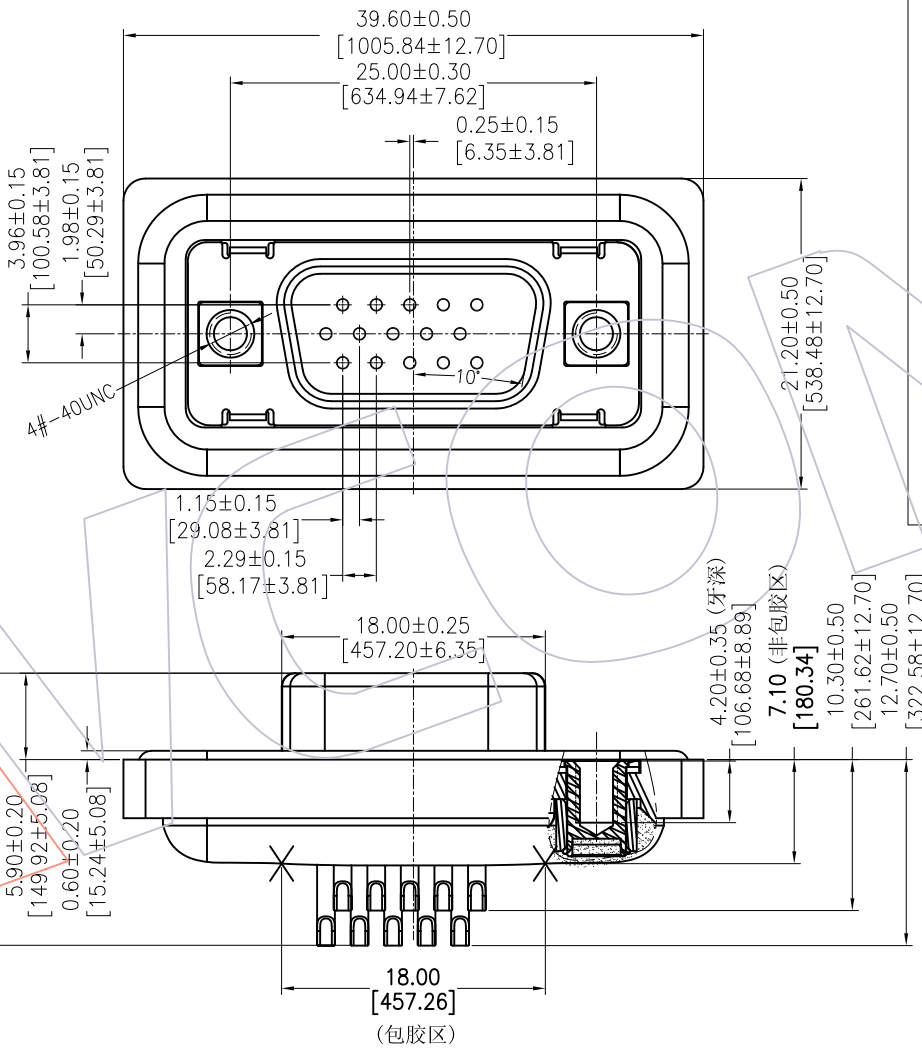
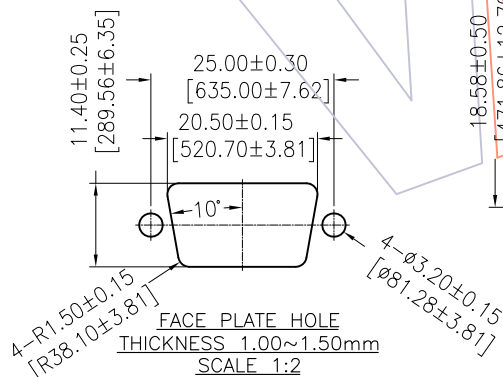

REV	DATE	MODIFICATION DESCRIPTION	CHANGE	OPERATION		DRAW	DATE	SCALE	FIT	PART NO.
				X.X	±0.40					
				X.XX	±0.25	DingWenMin	2016/11/01	UNIT	mm	6244-15MLXXFBX1
				X.XXX	±0.15	CHECK	DATE	SIZE	A4	
				Angle	± 3'	APPROVE	DATE	SHEET	1/2	TITLE:
				DIM	TOL			PROJ.	↗	D-SUB 15P MALE THREE ROWS 180° SOLDER TYPE WITH WATERPROFF

WCON

Http: www.wcon.com

WCON-Dongguan Tel: +86 769 85358920 Fax: +86 769 85358915 E-mail: sales@wcon.com	WCON-Kunshan Tel: +86 512 57468408 Fax: +86 512 57468468 E-mail: salesks@wcon.com
---	--