

HSF

NOTES:

1. ELECTRICAL:
 - 1.1 CONTACT CURRENT RATING: 3 AMPERES
 - 1.2 CONTACT RESISTANCE: 10 MILLIOHMS MAX.
 - 1.3 DIELECTRIC WITHSTANDING VOLTAGE: 800V AC FOR 1MINUTE
 - 1.4 INSULATION RESISTANCE: 5000 MEGOHMS MIN AT 500V DC
2. MECHANICAL:
 - 2.1 INSERTION FORCE: 340 g/f MAX
 - 2.2 SEPARATION FORCE: 21 g/f MIN
 - 2.3 SCREW COUNTER TORSION FORCE: 5.0 KgF.cm MIN.
3. ENVIRONMENTAL:
 - 3.1 TEMPERATURE RATING: -40°C TO +85°C.
 - 3.2 WATERPROFF CLASS: IP67
 - 3.3 AIRPROOF CAPABILITY: PRESSURE DROP 0.3 KPa MAX. AT 52.2 KPa FOR 3 MINUTE.
4. ALL MATERIALS SHOULD BE COMPLIANT TO ROHS

Ordering Information

6245-15 F X XX F B X 1

No. of Pins 15	Contact Plating G0=Gold Flash G3=10u"Gold G4=15u"Gold G5=30u"Gold	Waterproof Circle F=With Front Waterproof Circle B=With Back Waterproof Circle	Color B=Black W=With Cap	N=Without Cap W=With Cap
-------------------	---	--	--------------------------------	-----------------------------

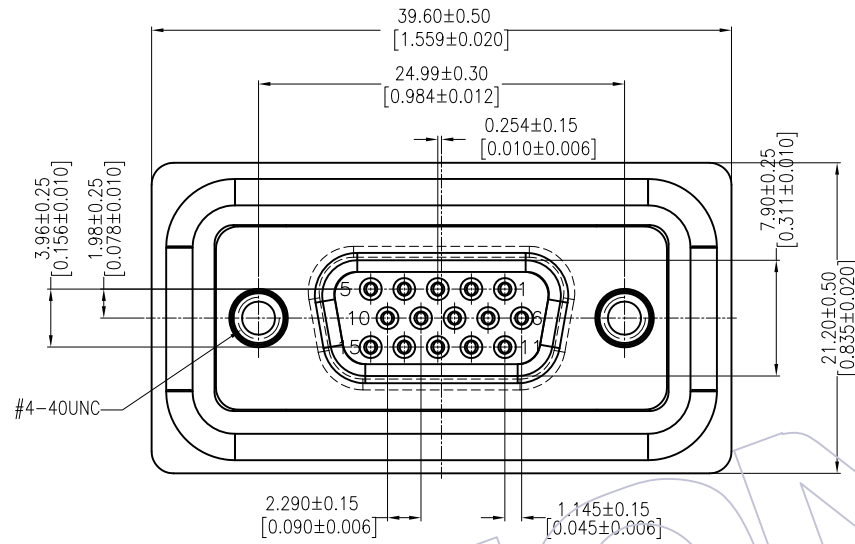
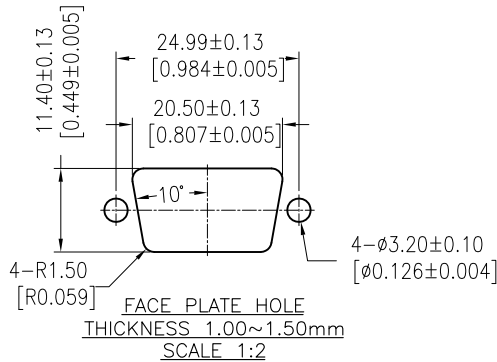

Recommended P.C.B Layout (Top Side)
(PCB BOARD TOLERANCE ± 0.05)

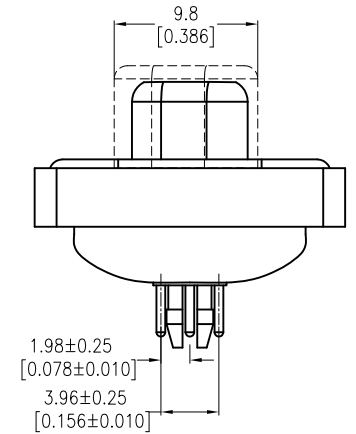
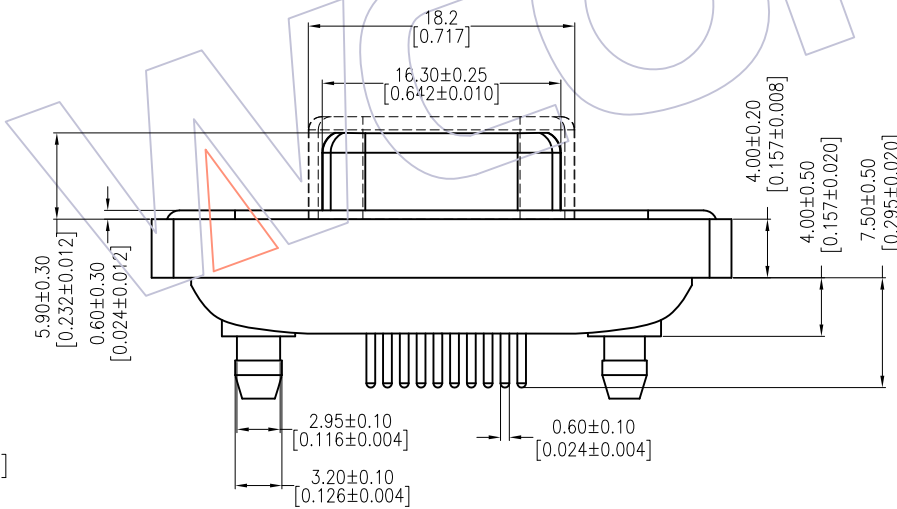
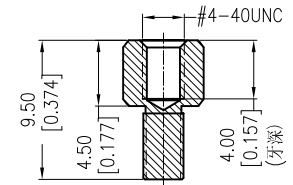
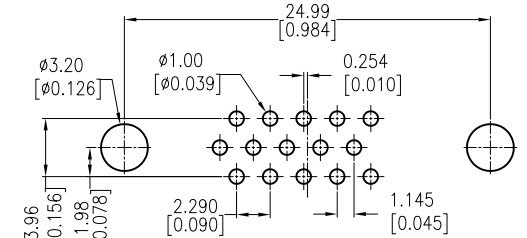

REV	DATE	MODIFICATION DESCRIPTION	CHANGE	OPERATION		DRAW	DATE	SCALE	FIT	PART NO.
				X.X	±0.40					
				X.XX	±0.25	Allen	2015/02/14	UNIT	mm	6245-15FXXXFBX1
				X.XXX	±0.15	CHECK	DATE	SIZE	A4	
				Angle	± 3'	APPROVE	DATE	SHEET	1/2	TITLE:
				DIM	TOL			PROJ.	↖	D-SUB 15P FEMALE THREE ROWS 180° DIP TYPE WITH WATERPROFF

WCON

Http: www.wcon.com

WCON-Dongguan Tel: +86 769 85358920 Fax: +86 769 85358915 E-mail: sales@wcon.com	WCON-Kunshan Tel: +86 512 57468408 Fax: +86 512 57468468 E-mail: sales@wcon.com
---	--

HSF

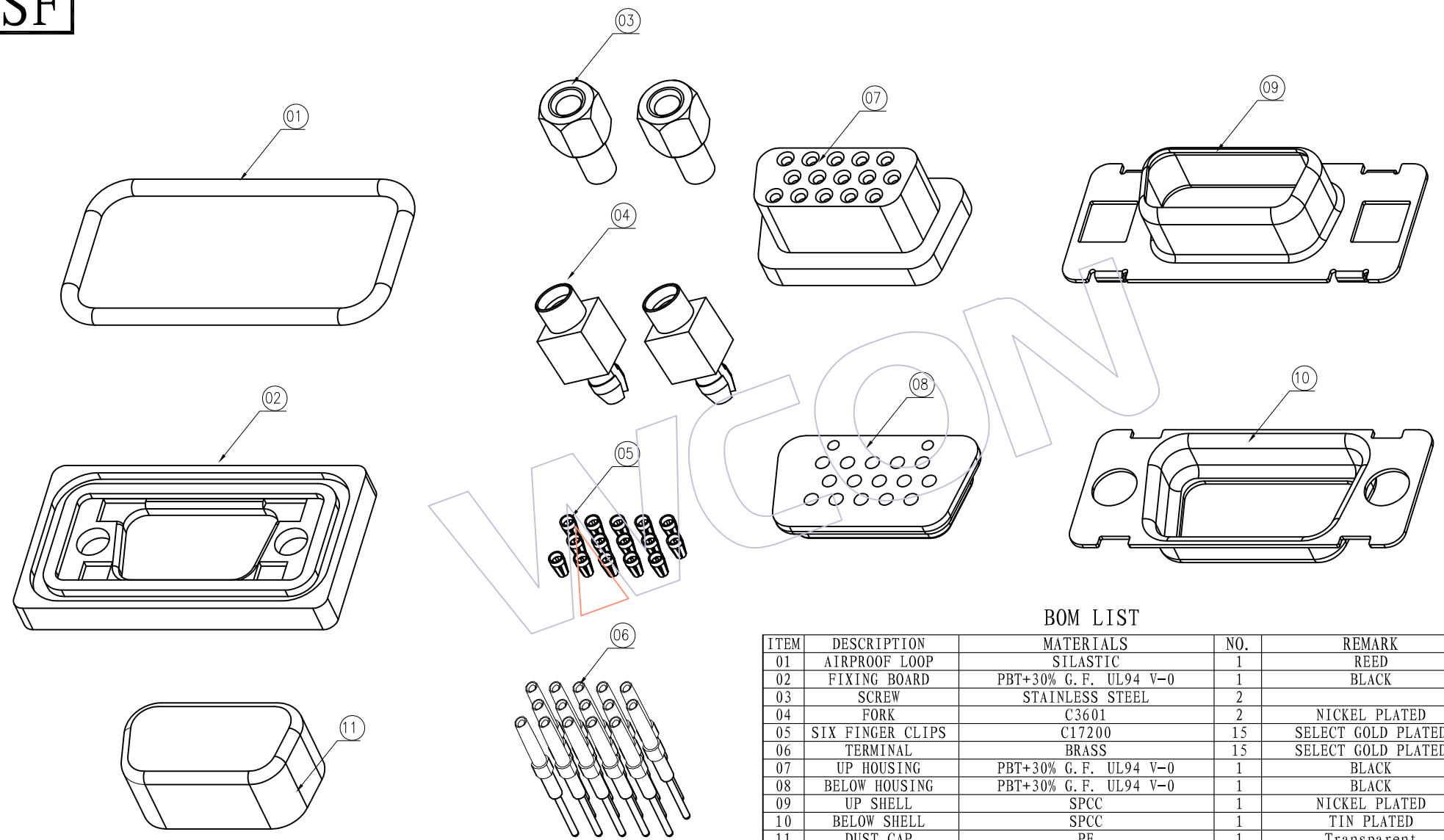

BOM LIST

ITEM	DESCRIPTION	MATERIALS	NO.	REMARK
01	AIRPROOF LOOP	SILASTIC	1	REED
02	FIXING BOARD	PBT+30% G. F. UL94 V-0	1	BLACK
03	SCREW	STAINLESS STEEL	2	
04	FORK	C3601	2	NICKEL PLATED
05	SIX FINGER CLIPS	C17200	15	SELECT GOLD PLATED
06	TERMINAL	BRASS	15	SELECT GOLD PLATED
07	UP HOUSING	PBT+30% G. F. UL94 V-0	1	BLACK
08	BELOW HOUSING	PBT+30% G. F. UL94 V-0	1	BLACK
09	UP SHELL	SPCC	1	NICKEL PLATED
10	BELOW SHELL	SPCC	1	TIN PLATED
11	DUST CAP	PE	1	Transparent

REV	DATE	MODIFICATION DESCRIPTION	CHANGE	OPERATION		DRAW	DATE	SCALE	FIT	PART NO.
				X.X	±0.40					
A0	2015/02/14	NEW		X.XX	±0.25	Allen	2015/02/14	UNIT	mm	6245-15FXXXFBX1
				X.XXX	±0.15	CHECK	DATE	SIZE	inch	
				Angle	± 3'	APPROVE	DATE	SHEET	2/2	TITLE:
				DIM	TOL			PROJ.	↺	D-SUB 15P FEMALE THREE ROWS 180° DIP TYPE WITH WATERPROFF

WCON
Http: www.wcon.com

WCON-Dongguan Tel: +86 769 85358920 Fax: +86 769 85358915 E-mail: sales@wcon.com	WCON-Kunshan Tel: +86 512 57468408 Fax: +86 512 57468468 E-mail: salesks@wcon.com
---	--

Customer NO.