

HSF

NOTES:

Current Rating: 3.0AMP
 Contact Resistance: 20mΩ Max
 Withstand Voltage: 500V AC/DC
 Insulation Resistance: 1000MΩ Min
 Operation Temperature: -55°C to +105°C
 Contact Material: Brass
 Contact plating: Au over Ni

Ordering Information

T6211 - M C 0 B XX 01

Contact Material
 B=Brass

Contact Plating
 G0=Gold Flash
 G3=10u"Gold
 G4=15u"Gold
 G5=30u"Gold

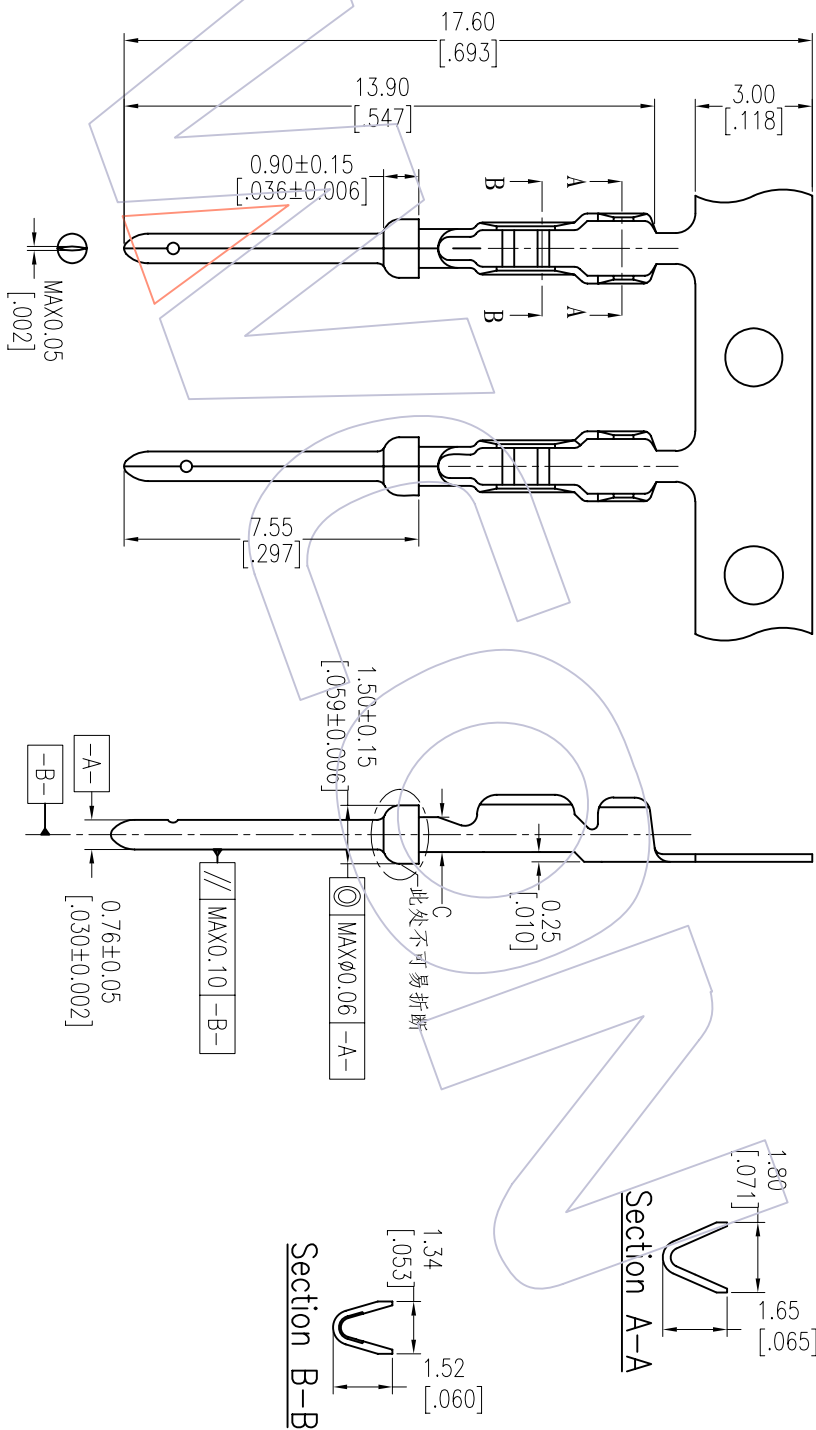

REV	DATE	MODIFICATION DESCRIPTION	CHANGE	OPERATION	DRAW	DATE	SCALE	FIT	PART NO.	TITLE:	WCON-Dongguan	WCON-Kunshan
A0	2013/01/08	NEW	-----	X.XX ±0.40	JYHuang	2013/01/08	mm	A4	T6211-MC0BXX01	HD-S0B CONNECTOR CRIMP TYPE MALE TERMINAL	Http: www.wcon.com	
				X.XXX ±0.15	CHECK	DATE	SIZE	A4				
				Angle ± 3'	APPROVE	DATE	SHEET	1/1	Customer NO.			
				DIM TOL			PROJ.					

WCON

Tel: +86 769 85358920
 Fax: +86 769 85358915
 E-mail: sales@wcon.com

Tel: +86 512 57468408
 Fax: +86 512 57468468
 E-mail: sales@wcon.com