

HSF

NOTES:

Rated Current:10 AMP
 Rated Voltage:300 V
 Contact Resistance:15 mΩ max
 Withstand Voltage:2000 V AC/DC
 Insulation Resistance:500 MΩ min DC500V
 Operation Temperature:-40°C to +105°C
 Torque value: 0.5N.m
 Operation Temperature:-40°C to +105°C
 Storage Temperature:-10°C to +40°C

Insulator Material:PA66 +25%GF(UL94 V-0)
 Terminal Material:Brass
 Terminal Plating:Sn Plated Over Nickel
 Screw material:C1018A
 Screw Plated: Ni Plating

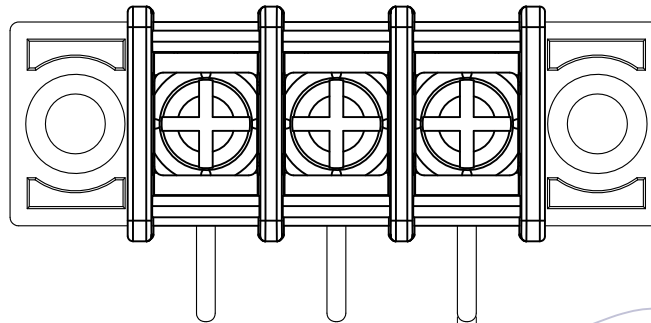

Recommended P.C.B Layout(Top Side)
 (PCB BOARD TOLERANCE±0.05)

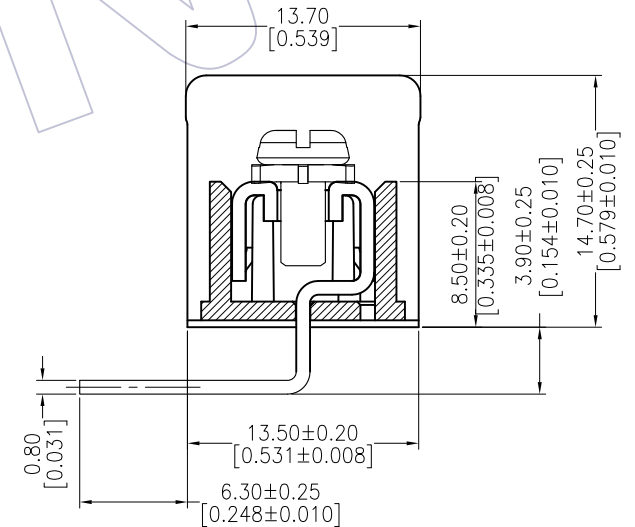
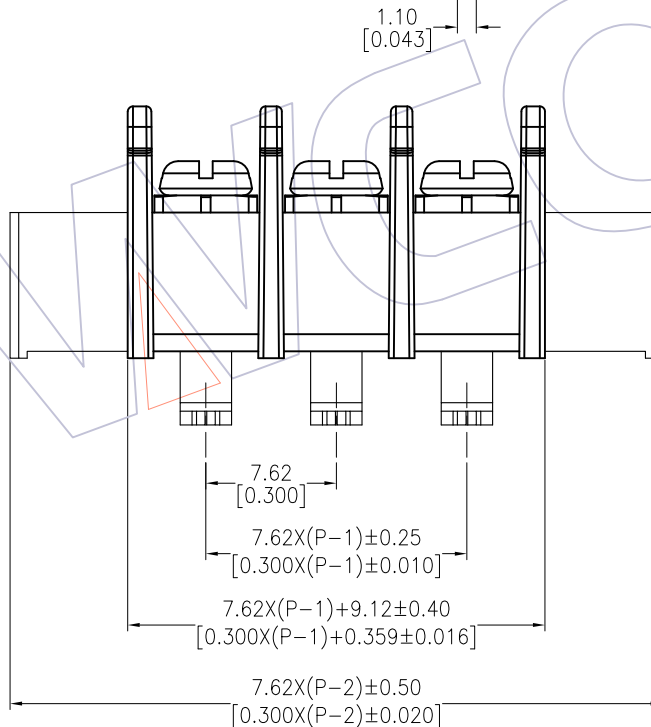
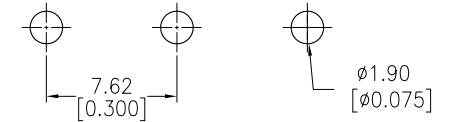

Ordering Information:

BH762- XX R XX X W N 01 N

No.of Pins: 02-33P
 Contact Plated: SN=Bright Tin
 Color: B=Black
 Contact Plated: N=Without CAP

REV	DATE	MODIFICATION DESCRIPTION	CHANGE	OPERATION		DRAW	DATE	SCALE	FIT	PART NO.	TITLE:	Customer NO.
				X.X	±0.40							
				X.XX	±0.25	Check	2015/09/16		A4	BH762-XXRXXWN01N	7.62 Pitch, Single-Row, C Type, W=13.50, H=14.70 Barrier Terminal Blocks	
				X.XXX	±0.15	APPROVE			1/1			
				Angle	± 3'							
				DIM	TOL							
A0	2015/09/16	NEW										



WCON-Dongguan
 Tel: +86 769 85358920
 Fax: +86 769 85358915
 E-mail: sales@wcon.com

WCON-Kunshan
 Tel: +86 512 57468408
 Fax: +86 512 57468468
 E-mail: sales@wcon.com