

# HSF

**NOTES:**

Rated Current:10 AMP  
 Rated Voltage:300 V  
 Contact Resistance:15 mΩ max  
 Withstand Voltage:2000 V AC/DC  
 Insulation Resistance:500 MΩ min DC500V  
 Operation Temperature:-40°C to +105°C  
 Torque value: 0.5N.m  
 Operation Temperature:-40°C to +105°C  
 Storage Temperature:-10°C to +40°C

Insulator Material:PA66 +25%GF(UL94 V-0)  
 CAP Material:PC(UL94 HB)  
 Terminal Material:Brass  
 Terminal Plating:Sn Plated Over Nickel  
 Screw material:C1018A  
 Screw Plated: Ni Plating

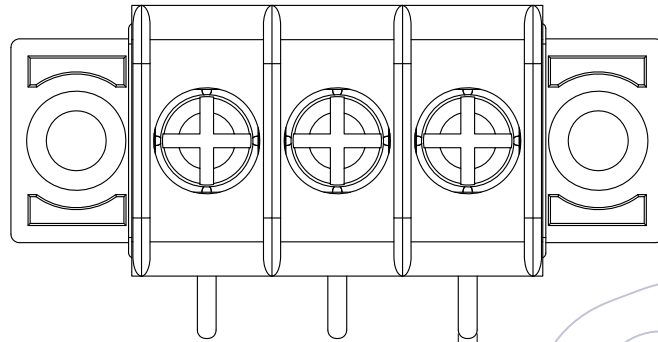

Recommended P.C.B Layout(Top Side)  
 (PCB BOARD TOLERANCE±0.05)

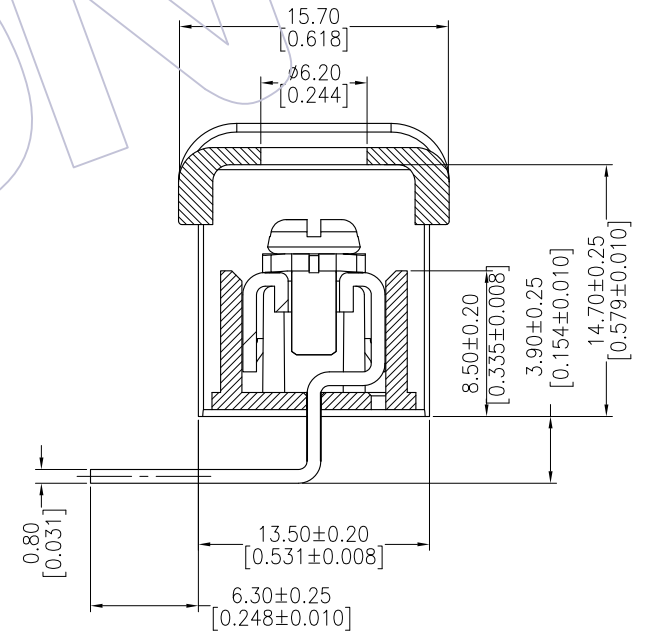
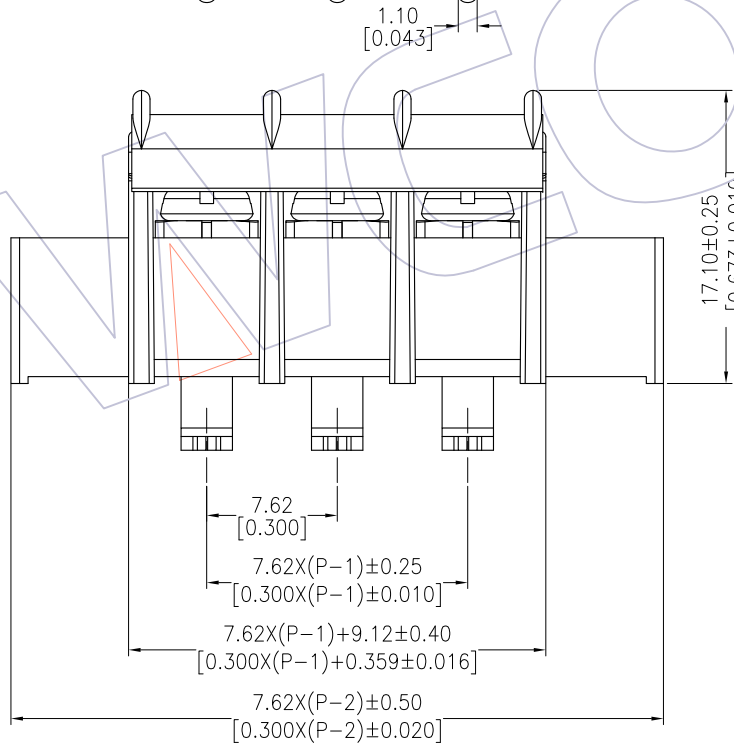
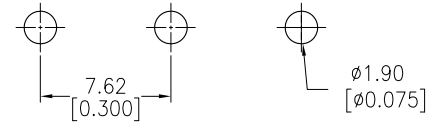

**Ordering Information:**

BH762- XX R XX X W W 01 N

No.of Pins: 02-33P  
 Contact Plated: SN=Bright Tin  
 Color: B=Black  
 Contact Plated: W=With CAP

REV	DATE	MODIFICATION DESCRIPTION	CHANGE	OPERATION		DRAW	DATE	SCALE	FIT	PART NO.	TITLE:	Customer NO.
				X.X	±0.40							
A0	2015/09/16	NEW		X.XX	±0.25	Allen	2015/09/16	UNIT	inch	BH762-XXRXXW01N	7.62 Pitch, Single-Row, C Type, W=13.50, H=14.70 Barrier Terminal Blocks	
				X.XXX	±0.15	CHECK		SIZE	A4			
				Angle	± 3'	APPROVE		SHEET	1/1			
				DIM	TOL			PROJ.				

**WCON**  
 Http: www.wcon.com

WCON-Dongguan  
 Tel: +86 769 85358920  
 Fax: +86 769 85358915  
 E-mail: sales@wcon.com

WCON-Kunshan  
 Tel: +86 512 57468408  
 Fax: +86 512 57468468  
 E-mail: salesks@wcon.com