

# HSF

**NOTES:**

Rated Current:10 AMP  
 Rated Voltage:300 V  
 Contact Resistance:15 mΩ max  
 Withstand Voltage:2000 V AC/DC  
 Insulation Resistance:500 MΩ min DC500V  
 Operation Temperature:-40°C to +105°C  
 Torque value: 0.5N.m  
 Operation Temperature:-40°C to +105°C  
 Storage Temperature:-10°C to +40°C

Insulator Material:PA66 +25%GF(UL94 V-0)  
 Terminal Material:Brass  
 Terminal Plating:Sn Plated Over Nickel  
 Screw material:C1018A  
 Screw Plated: Ni Plating

Recommended P.C.B Layout(Top Side)  
 (PCB BOARD TOLERANCE±0.05)

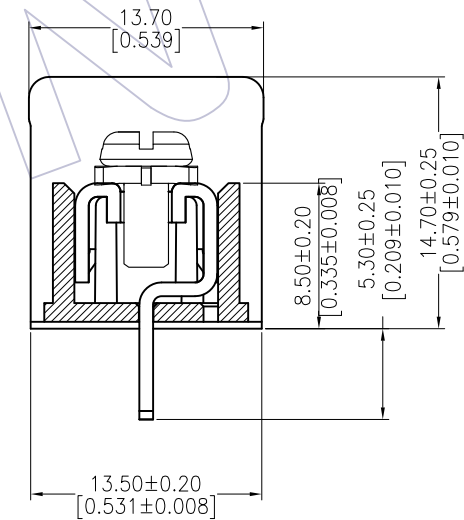
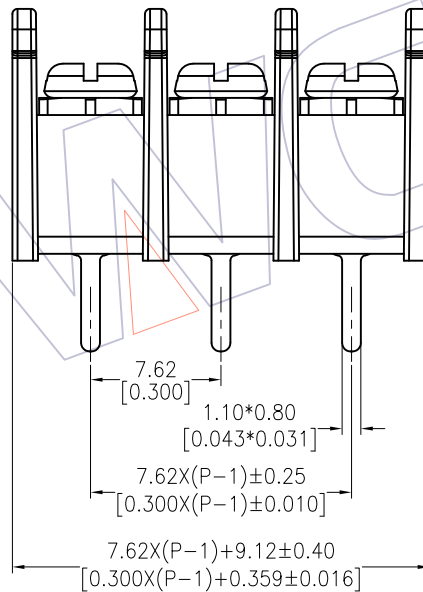
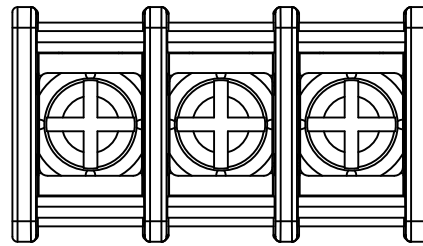
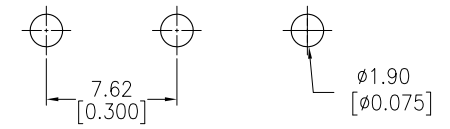

**Ordering Information:**

BH762- XX S XX X N N 01 N

No. of Pins: 02-33P  
 Contact Plated: SN=Bright Tin  
 Color: B=Black  
 Contact Plated: N=Without CAP

| REV | DATE       | MODIFICATION DESCRIPTION | CHANGE | OPERATION |       | DRAW    | DATE | SCALE | FIT  | PART NO.          | TITLE:   | Customer NO.           |                        |
|-----|------------|--------------------------|--------|-----------|-------|---------|------|-------|------|-------------------|--|------------------------|------------------------|
|     |            |                          |        | X.X       | ±0.40 |         |      |       |      |                   |  |                        | Allen                  |
| A0  | 2015/09/16 | NEW                      |        | X.XX      | ±0.25 | CHECK   | DATE | UNIT  | inch | BH762-XXSXXXNN01N | 7.62 Pitch, Single-Row, A Type, W=13.50, H=14.70 Barrier Terminal Blocks | Tel: +86 769 85358920  | Tel: +86 512 57468408  |
|     |            |                          |        | X.XXX     | ±0.15 | APPROVE | DATE | SIZE  | A4   |                   |  | Fax: +86 769 85358915  | Fax: +86 512 57468468  |
|     |            |                          |        | Angle     | ± 3'  |         |      | SHEET | 1/1  |                   |  | E-mail: sales@wcon.com | E-mail: sales@wcon.com |
|     |            |                          |        | DIM       | TOL   |         |      | PROJ. | ⌀    |                   |  |                        |                        |



WCON-Dongguan  
 Tel: +86 769 85358920  
 Fax: +86 769 85358915  
 E-mail: sales@wcon.com

WCON-Kunshan  
 Tel: +86 512 57468408  
 Fax: +86 512 57468468  
 E-mail: sales@wcon.com