

HSF

NOTES:

Rated Current:10 AMP
 Rated Voltage:300 V
 Contact Resistance:15 mΩ max
 Withstand Voltage:2000 V AC/DC
 Insulation Resistance:500 MΩ min DC500V
 Operation Temperature:-40℃ to +105℃
 Torque value: 0.5N.m
 Operation Temperature:-40℃ to +105℃
 Storage Temperature:-10℃ to +40℃

Insulator Material:PA66 +25%GF(UL94 V-0)
 Terminal Material:Brass
 Terminal Plating:Sn Plated Over Nickel
 Screw material:C1018A
 Screw Plated: Ni Plating

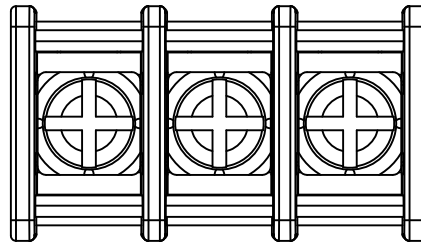

Recommended P.C.B Layout(Top Side)
 (PCB BOARD TOLERANCE±0.05)

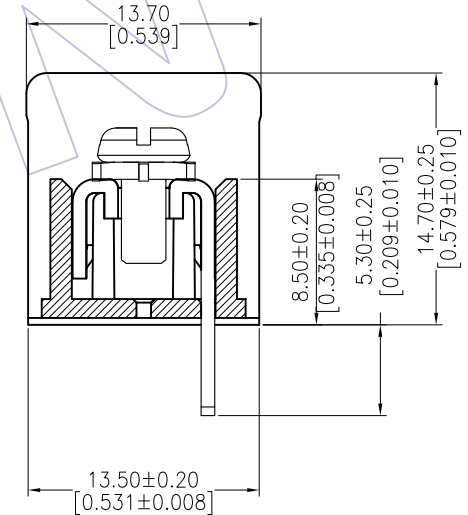
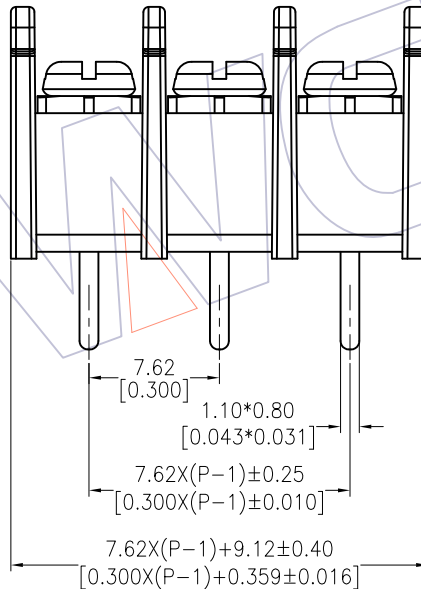
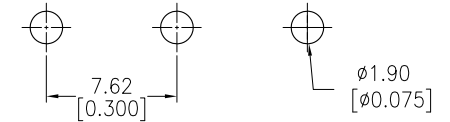

Ordering Information:

BH762- XX S XX X N N 02 N

No.of Pins: 02-33P
 Contact Plated: SN=Bright Tin
 Color: B=Black
 Contact Plated: N=Without CAP

			OPERATION		DRAW		DATE		SCALE		FIT		PART NO.		
			X.X ±0.40		Allen		2015/09/16		UNIT		mm		BH762-XXSXXXNN02N		
			X.XX ±0.25		CHECK		DATE		SIZE		A4		TITLE: 7.62 Pitch, Single-Row, B Type, W=13.50, H=14.70 Barrier Terminal Blocks		
A0 2015/09/16			NEW		APPROVE		DATE		SHEET		1/1		Customer NO.		
REV		DATE		MODIFICATION DESCRIPTION		CHANGE		Angle ± 3°		DIM		TOL		WCON	
														Http: www.wcon.com WCON-Dongguan Tel: +86 769 85358920 WCON-Kunshan Tel: +86 512 57468408 Fax: +86 769 85358915 Fax: +86 512 57468468 E-mail: sales@wcon.com E-mail: salesks@wcon.com	