

- NOTES:
1. Body material: PBT+G.F, UL94 V-0
 2. Contact material: Phosphor bronze, Plated: Gold Flash/Ni
 3. Pin material: Brass, Plated: Gold Flash
 4. Screw material: Steel, Plated: Ni
 5. Rated Voltage: 300V
 6. Rated Current: 10A
 7. Wire Range: 14-22AWG
 8. Screw Torque: 7.0lbf.in
 9. Contact Resistance: 8mΩ Max
 10. Insulation Resistance: DC1000V 1000MΩ Min
 11. Power-Frequency Withstand Voltage: AC2500V/1min
 12. Impulse Withstand Voltage: 3000V
 13. Operation Temperature: -40°C to +120°C

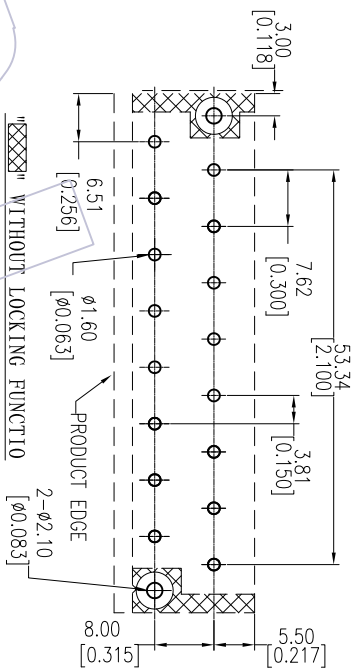
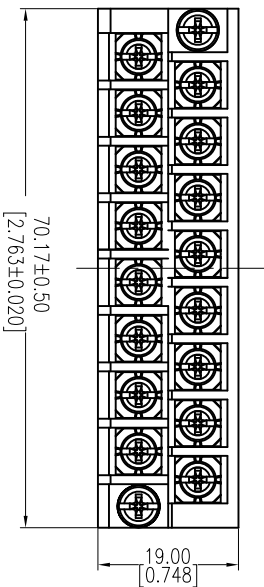

Ordering Information:

BH762-00-08-G-G0-S01

△ No. Pin Per Row
08P

Color:

G=Grey

G=Gold Flash

Contact Plated:

G=Gold Flash

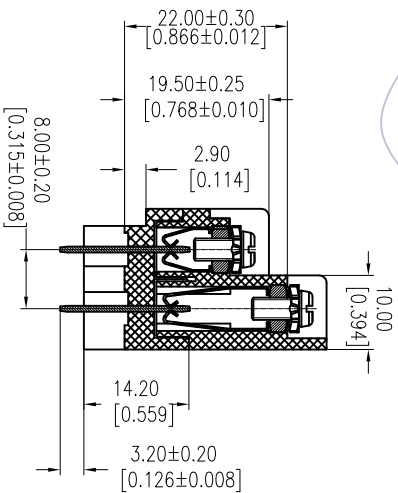
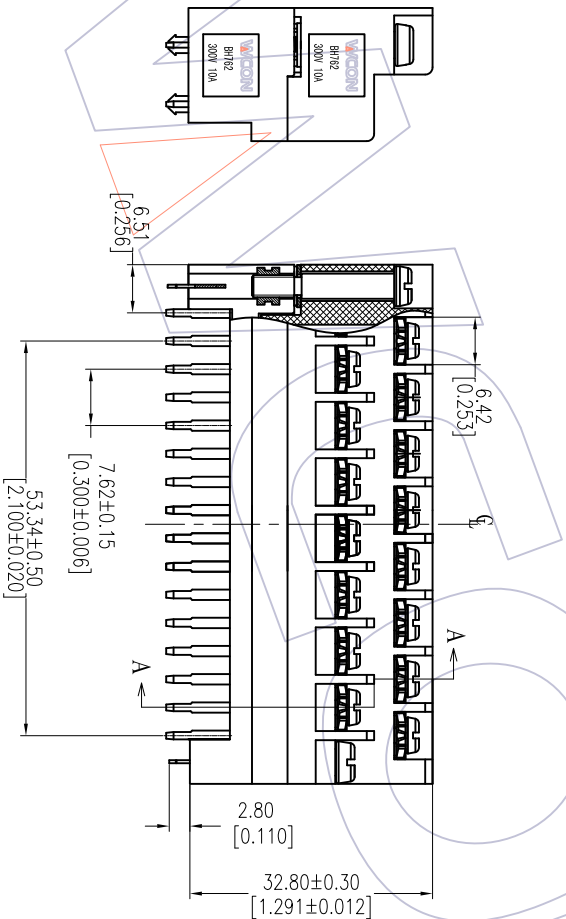

SECTION A-A

REV	DATE	MODIFICATION DESCRIPTION	CHANGE	OPERATION		DRAW		DATE		SCALE		PART NO.		TITLE:	
				XX	±0.40	Tsingn	2013/09/23	mm	inch	BH762-00-08-G-G0-S01	7.62Pitch*8.00mm, Double-Row, W19.00mm*H32.80mm, 08 Pin Pairs Barrier Terminal Blocks				
A1	2013/09/23	Modify	△	XX	±0.25	CHECK	DATE	A4		mm	inch	Customer NO.	WCON-Dongguan Tel: +86 769 85358920 Fax: +86 512 57468408 Http: www.wcon.com		
A0	2013/03/05	NEW		XX	±0.15	APPROVE	DATE	1/1		mm	inch		WCON-Kunshan Tel: +86 512 57468408 Fax: +86 512 57468468 E-mail: sales@wcon.com		



WCON-Dongguan
Tel: +86 769 85358920 Fax: +86 512 57468408
Http: www.wcon.com

WCON-Kunshan
Tel: +86 512 57468408 Fax: +86 512 57468468
E-mail: sales@wcon.com