

HSF

NOTES:

Rated Current:18.0 AMP
 Contact Resistance:8 mΩ Max
 Withstand Voltage:2000 V AC/DC
 Insulation Resistance:1000 MΩ min
 Operation Temperature:-40℃ to +105℃
 Wire Range:30~12 AWG
 Wire Strip Length: 7 mm
 No.of Positions:2~20
 Screw Counter Torsion Force: 4.4 lbf.in Min.

Terminal Material:Phosphor Bronze
 Terminal Plating:Matte Tin Plated Over Nickel
 Pin Block Material:Brass
 Pin Block Plating:Nickel Plated Over All
 Screw Material: Steel
 Screw Plating:Nickel Plated Over All
 Up Cover Material:PA66 UL94 V-0
 Below Cover Material:PA66 UL94 V-0

2P Without RAMP Locking "A"

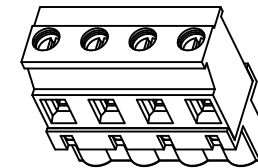
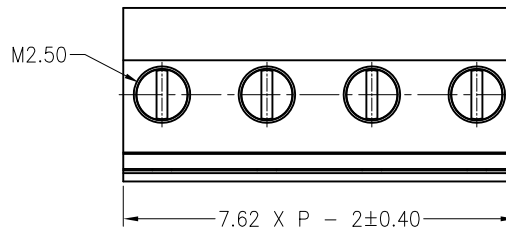

3D VIEW(REF.)
SCALE 1:2

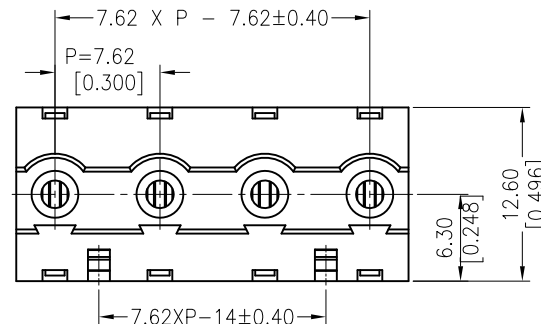
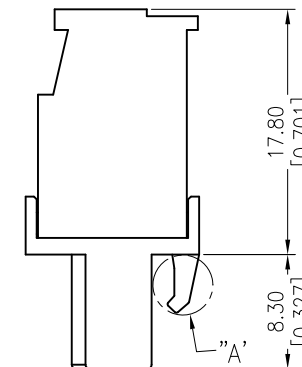
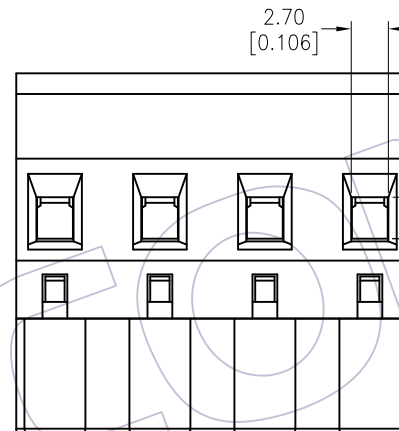

Ordering Information:

P F 762 - A XX A SM N 1

F=Female Pitch 762=7.62
 No.of Pins 02-20P
 Color A=Green
 Contact Plated SM=Matte Tin
 Type N=Without Two Side Screw

REV	DATE	MODIFICATION DESCRIPTION	CHANGE	OPERATION		DRAW	DATE	SCALE	FIT	PART NO.
				X.X	±0.40					
A1	2015/07/15	Modify	△	X.XX	±0.25	Allen	2015/07/15	UNIT	mm	PF762-AXXASMN1
A0	2013/07/17	NEW	—	X.XXX	±0.15	CHECK	DATE	SIZE	A4	
				Angle	± 3'	APPROVE	DATE	SHEET	1/1	TITLE:
				DIM	TOL			PROJ.	↖	7.62mm Pitch Female Pluggable Terminal Blocks
										Customer NO.

WCON

Http: www.wcon.com

WCON-Dongguan Tel: +86 769 85358920 Fax: +86 769 85358915 E-mail: sales@wcon.com
 WCON-Kunshan Tel: +86 512 57468408 Fax: +86 512 57468468 E-mail: salesks@wcon.com