

HSF

NOTES:

Rated Current:18.0 AMP
 Contact Resistance:8 mΩ Max
 Withstand Voltage:2000 V AC/DC
 Insulation Resistance:1000 MΩ min
 Operation Temperature:-40°C to +105°C
 Wire Range:30~12 AWG
 Wire Strip Length: 7 mm
 No.of Positions:2~20
 Screw Counter Torsion Force: 4.4 lbf.in Min.

Terminal Material:Phosphor Bronze
 Terminal Plating:Matte Tin Plated Over Nickel
 Pin Block Material:Brass
 Pin Block Plating:Nickel Plated Over All
 Screw Material: Steel
 Screw Plating:Nickel Plated Over All
 Up Cover Material:PA66 UL94 V-0
 Below Cover Material:PA66 UL94 V-0

2P Without RAMP Locking "A"

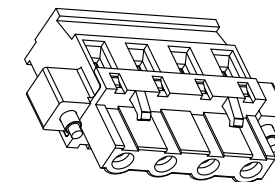
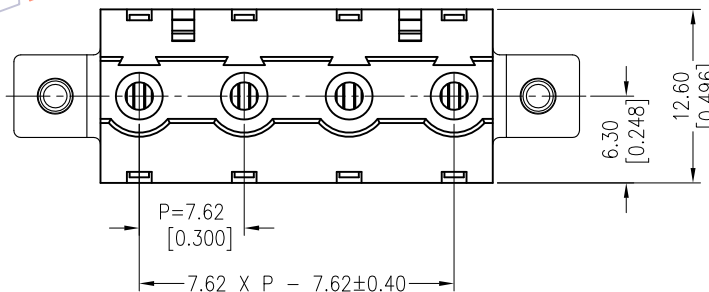
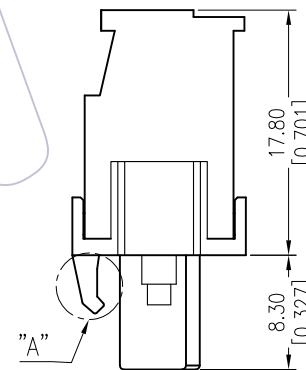
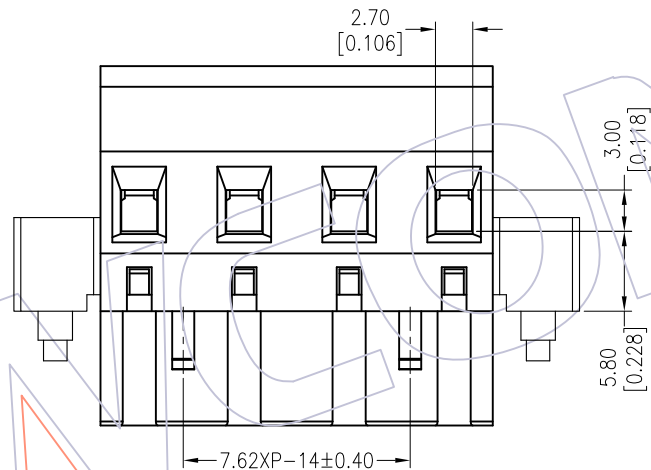
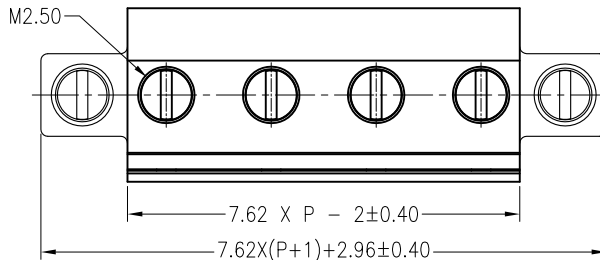

3D VIEW(REF.)
SCALE 1:2

Ordering Information:

P F 762 - B XX A SM W 1

F=Female Pitch 762=7.62
 No.of Pins 02-20P
 Color A=Green
 Contact Plated SM=Matte Tin
 Type W=With Screw

REV	DATE	MODIFICATION DESCRIPTION	CHANGE	OPERATION		DRAW	DATE	SCALE	FIT	PART NO.	TITLE:	WCON	
				X.X	±0.40							UNIT	mm
A1	2015/07/15	Modify	△	X.XX	±0.25	Allen	2015/07/15	UNIT	mm	PF762-BXXASMW1	7.62mm Pitch Female Pluggable Terminal Blocks	Tel: +86 769 85358920	Tel: +86 512 57468408
A0	2013/07/17	NEW	—	X.XXX	±0.15	CHECK	DATE	SIZE	A4	Customer NO.		Fax: +86 769 85358915	Fax: +86 512 57468468
				Angle	± 3'	APPROVE	DATE	SHEET	1/1			E-mail: sales@wcon.com	E-mail: salesks@wcon.com
				DIM	TOL			PROJ.					

WCON

Http: www.wcon.com

WCON-Dongguan
Tel: +86 769 85358920
Fax: +86 769 85358915
E-mail: sales@wcon.com

WCON-Kunshan
Tel: +86 512 57468408
Fax: +86 512 57468468
E-mail: salesks@wcon.com