

# HSF

**NOTES:**

Rated Current:18.0 AMP  
 Contact Resistance:8 mΩ Max  
 Withstand Voltage:2000 V AC/DC  
 Insulation Resistance:1000 MΩ min  
 Operation Temperature:-40°C to +105°C  
 Wire Range:30~12 AWG  
 Wire Strip Length: 7 mm  
 No.of Positions:2~20  
 Screw Counter Torsion Force: 4.4 lbf.in Min.

Terminal Material:Phosphor Bronze  
 Terminal Plating:Matte Tin Plated Over Nickel  
 Pin Block Material:Brass  
 Pin Block Plating:Nickel Plated Over All  
 Screw Material: Steel  
 Screw Plating:Nickel Plated Over All  
 Up Cover Material:PA66 UL94 V-0  
 Below Cover Material:PA66 UL94 V-0

2P Without RAMP Locking "A"

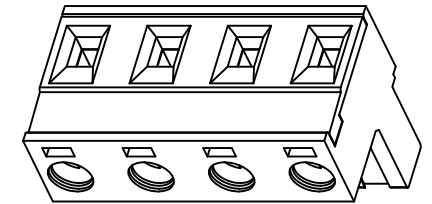
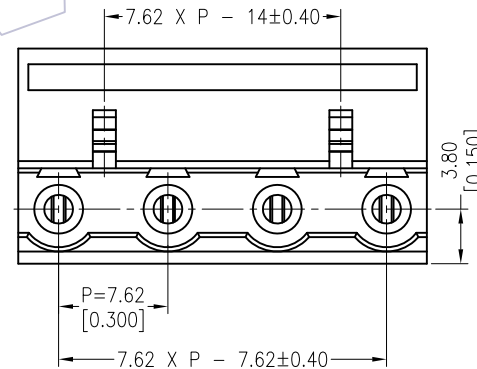
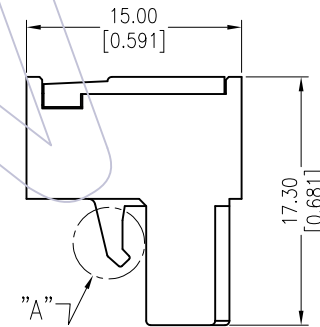
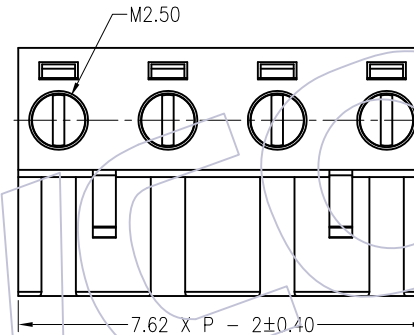
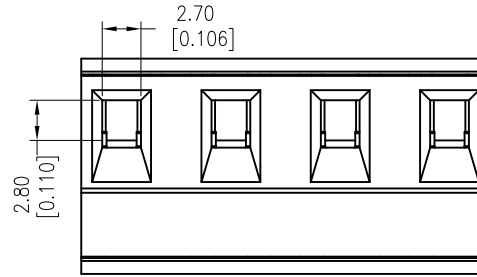

3D VIEW(REF.)

## Ordering Information:

**P F 762 - C XX A SM N 1**

F=Female Pitch 762=7.62  
 No.of Pins 02-20P  
 Color A=Green SM=Matte Tin  
 Type N=Without Two Side Screw

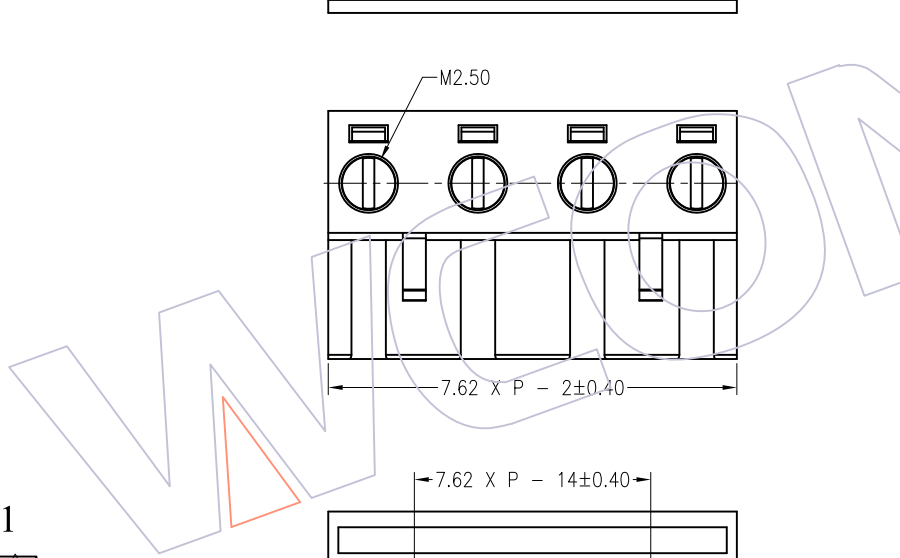

REV	DATE	MODIFICATION DESCRIPTION	CHANGE	OPERATION		DRAW	DATE	SCALE	FIT	PART NO.	TITLE:	WCON	
				X.X	±0.40							Allen	2015/07/15
A1	2015/07/15	Modify	△	X.XX	±0.25	CHECK	DATE	UNIT	inch	PF762-CXXASMN1	7.62mm Pitch Female Pluggable Terminal Blocks	Tel: +86 769 85358920	Tel: +86 512 57468408
A0	2013/07/17	NEW	—	X.XXX	±0.15	APPROVE	DATE	SIZE	A4			Fax: +86 769 85358915	Fax: +86 512 57468468
				Angle	± 3'					SHEET	1/1	E-mail: sales@wcon.com	E-mail: salesks@wcon.com
				DIM	TOL			PROJ.	⌀	Customer NO.			

# WCON

Http: www.wcon.com

WCON-Dongguan Tel: +86 769 85358920 Fax: +86 769 85358915 E-mail: sales@wcon.com  
 WCON-Kunshan Tel: +86 512 57468408 Fax: +86 512 57468468 E-mail: salesks@wcon.com