

HSF

NOTES:

Rated Current:2.0AMP.
 Contact Resistance:20mΩ Max.
 Withstand Voltage:500V AC/DC
 Insulation Resistance:1000MΩ Min.
 Operation Temperature:-40°C to +105°C

Contact Material:Brass
 Contact Plating:Au or Sn Over Ni
 Insulator Material:PA9T+33%G.F UL94V-0 BK

Recommended P.C.B Layout (Top Side)
 (PCB BOARD TOLERANCE±0.05)

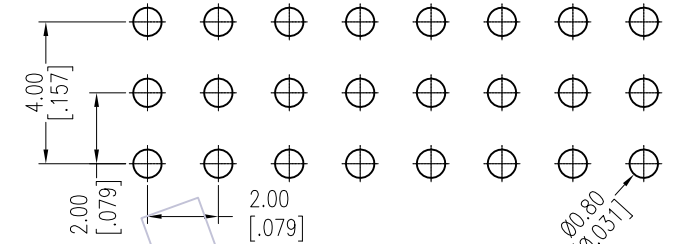
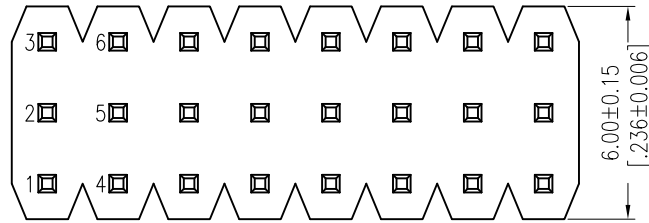

Ordering Information

1215-23 XX XX S XXX C 0 XX

No. of Pins Per Row:03~50	Contact Plating G0=Gold Flash G3=10u"Gold G4=15u"Gold G5=30u"Gold	Pin Length L=A+B+C Standard:	Insulator Material C=PA9T	Packing 0=PE Bag T=Tube	Series No. 01~99
	S0=Gold Flash/Tin S3=10u"Gold/Tin S4=15u"Gold/Tin S5=30u"Gold/Tin				
	SN=Tin SM=Matte Tin				

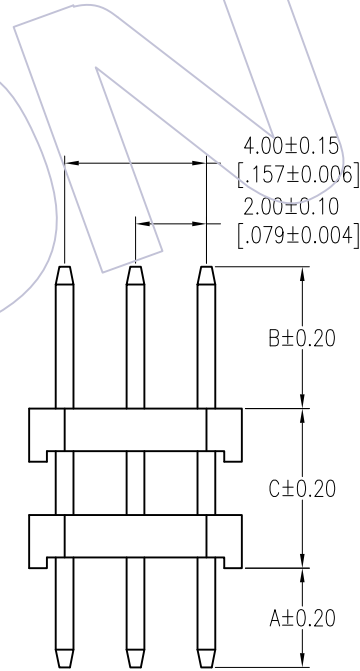
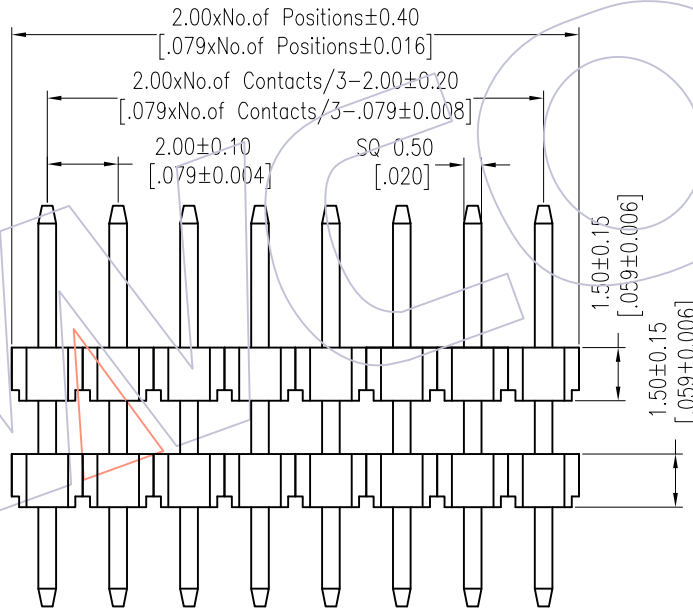

TYPE 1

TYPE 2

Item	Pin Length	A	B	C	Mating
Standard	---	2.80	4.00	---	2263
Alternate					

REV	DATE	MODIFICATION DESCRIPTION	CHANGE	OPERATION	DRAW	DATE	SCALE	Fit	PART NO.
				x.X ±0.40	Liu	2018.01.18	UNIT	mm	1215-23XXXXXXCXXX
A1	2018/01/18	Modify P/N	△	x.XX ±0.25	CHECK	DATE	SIZE	A4	TITLE: PH2.00 THREE ROW DOUBLE PLASTIC 180° H=1.5
A0	2012/04/18	NEW	----	x.XXX ±0.15	APPROVE	DATE	SHEET	1/1	Customer NO.
				Angle ± 3'			PROJ.		
				DIM TOL					



Http: www.wcon.com

WCON-Dongguan Tel: +86 769 85358920 Fax: +86 769 85358915 E-mail: sales@wcon.com	WCON-Kunshan Tel: +86 512 57468408 Fax: +86 512 57468468 E-mail: salesks@wcon.com
---	--