

HSF

Recommended P.C.B Layout (Top Side)
(PCB BOARD TOLERANCE±0.05)

NOTES:
Rated Current:3.0AMP.
Contact Resistance:20mΩ Max.
Withstand Voltage:1000V AC/DC
Insulation Resistance:1000MΩ Min.
Operation Temperature:-40°C to +105°C

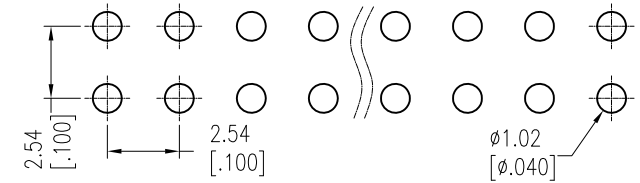
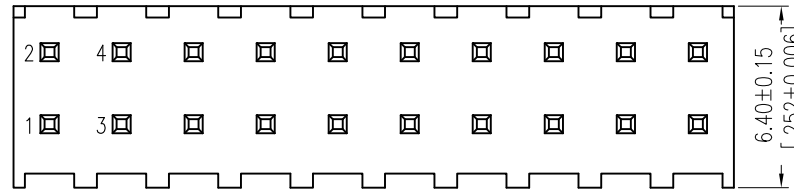

Contact Material:Brass
Contact Plating:Au or Sn Over Ni
Insulator Material:PA9T+33%G.F UL94V-0 BK

Ordering Information

1174-12 XX XX S XXX C 0 XX

No. of Pins Per Row:02~40	Contact Plating G0=Gold Flash G3=10u"Gold G4=15u"Gold G5=30u"Gold S0=Gold Flash/Tin S3=10u"Gold/Tin S4=15u"Gold/Tin S5=30u"Gold/Tin SN=Tin SM=Matte Tin	Pin Length L=A+B+7.4 Standard:164=16.4	Insulator Material C=PA9T	Packing 0=PE Bag T=Tube	Series No. 01~99
------------------------------	---	--	---------------------------------	-------------------------------	---------------------

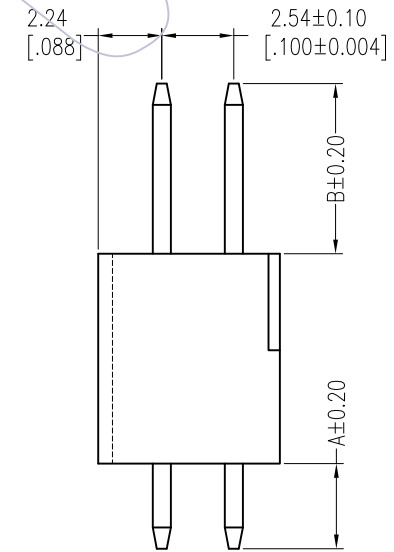
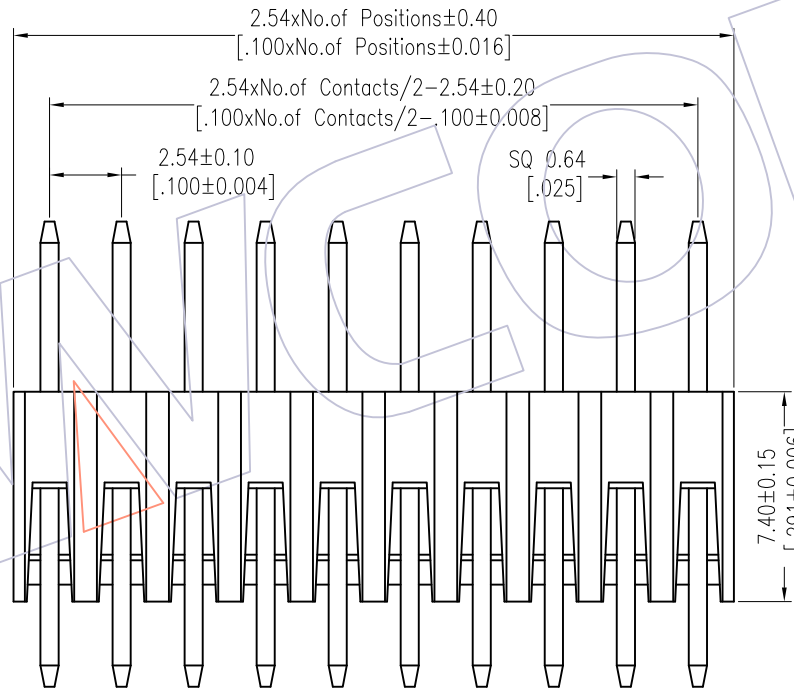

Item	Pin Length	A	B
Standard	16.40	3.00	6.00
Alternate			

REV	DATE	MODIFICATION DESCRIPTION	CHANGE	DIM	TOL	OPERATION	DRAW	DATE	SCALE	Fit	PART NO.
A3	2018/01/22	Modify P/N		x.x	±0.40	OPERATION	DRAW	2018/01/22	UNIT	mm	1174-12XXXXXXCOXX
A2	2013/03/01	Modify The Material		x.xx	±0.25	CHECK	Ruipeng	DATE	SIZE	A4	TITLE:
A1	2012/12/13	Add PBT Material		x.xxx	±0.15	APPROVE		DATE	SHEET	1/1	PH2.54 DUAL ROW 180°H=7.4
A0	2012/05/08	NEW	-----	Angle	± 3'			DATE	PROJ.		Customer NO.

WCON

Http: www.wcon.com

WCON-Dongguan Tel: +86 769 85358920 Fax: +86 769 85358915 E-mail: sales@wcon.com	WCON-Kunshan Tel: +86 512 57468408 Fax: +86 512 57468468 E-mail: salesks@wcon.com
---	--