

# HSF

**NOTES:**

Rated Current:2.0AMP.  
 Contact Resistance:20mΩ Max.  
 Withstand Voltage:500V AC/DC  
 Insulation Resistance:1000MΩ Min.  
 Operation Temperature:-40°C to +105°C

Contact Material:Brass  
 Contact Plating:Au or Sn Over Ni  
 Insulator Material:PA9T+33%G.F UL94V-0 BK

## Ordering Information

1215-22 XX XX S XXX C 0 XX

No.of Pins Per Row:02~50	Contact Plating G0=Gold Flash G3=10u"Gold G4=15u"Gold G5=30u"Gold S0=Gold Flash/Tin S3=10u"Gold/Tin S4=15u"Gold/Tin S5=30u"Gold/Tin SN=Tin SM=Matte Tin	Pin Length L=A+B+C Standard:	Insulator Material C=PA9T	Packing 0=PE Bag T=Tube	Series No. 01~99
-----------------------------	---	------------------------------------	---------------------------------	-------------------------------	---------------------

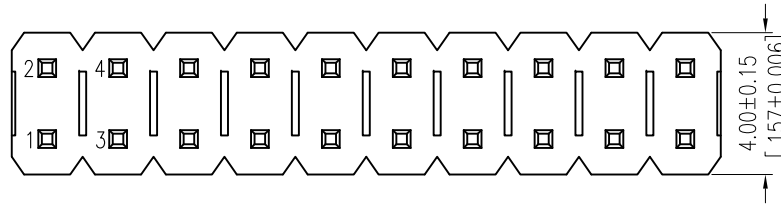

Recommended P.C.B Layout (Top Side)  
 (PCB BOARD TOLERANCE±0.05)

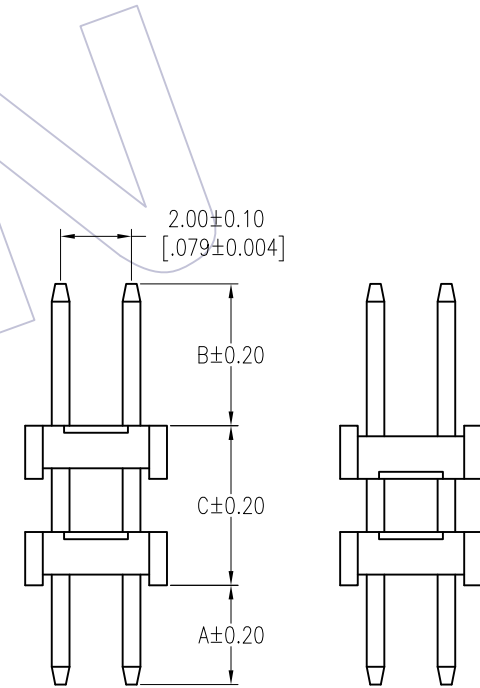
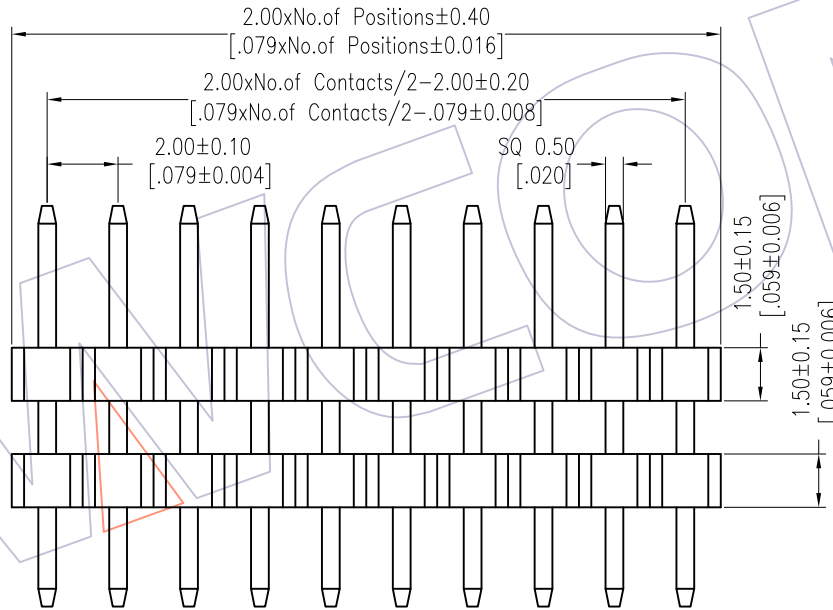
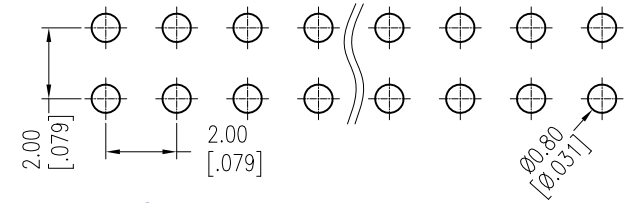

Item	Pin Length	A	B	C	Mating
Standard	---	2.80	2.00	---	2220T 2221 2227T 2228
	---	2.80	3.00	---	2235
	---	2.80	4.00	---	2240 2243 2263 2272
Alternate					

REV	DATE	MODIFICATION DESCRIPTION	CHANGE	OPERATION	DRAW	DATE	SCALE	Fit	PART NO.
A1	2018/01/18	Modify P/N		x.X ±0.40	Liu	2018.01.18	UNIT mm		1215-22XXXXXXC0XX
AO	2012/04/18	NEW	-----	x.XX ±0.25	CHECK	DATE	SIZE A4		TITLE: PH2.00 DUAL ROW DOUBLE PLASTIC 180° H=1.5
				x.XXX ±0.15	APPROVE	DATE	SHEET 1/1		Customer NO.
				Angle ± 3'			PROJ.		
				DIM TOL					

**WCON**  
 Http: www.wcon.com

WCON-Dongguan Tel: +86 769 85358920 Fax: +86 769 85358915 E-mail: sales@wcon.com

WCON-Kunshan Tel: +86 512 57468408 Fax: +86 512 57468468 E-mail: salesks@wcon.com