

HSF

NOTES:

Rated Current:3.0AMP.
 Contact Resistance:20mΩ Max.
 Withstand Voltage:1000V AC/DC
 Insulation Resistance:1000MΩ Min.
 Operation Temperature:-40°C to +105°C

Contact Material:Brass
 Contact Plating:Au or Sn Over Ni
 Insulator Material:PA9T+33%G.F UL94V-0 BK

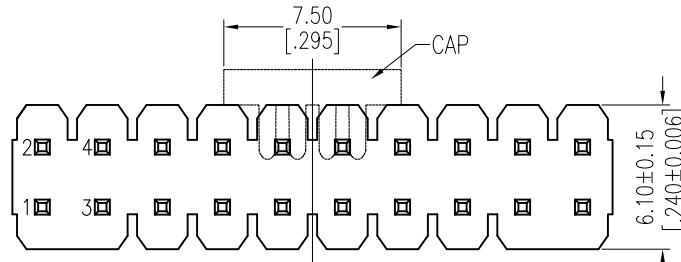

Dual Numbers

Recommended P.C.B Layout (Top Side)
 (PCB BOARD TOLERANCE±0.05)

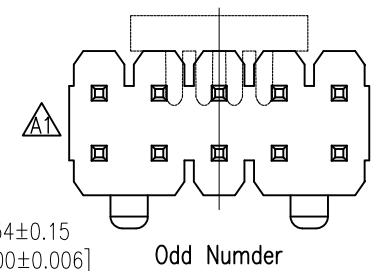
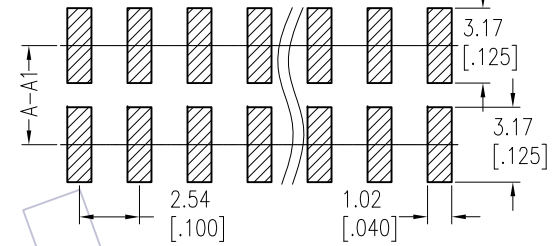

Odd Number

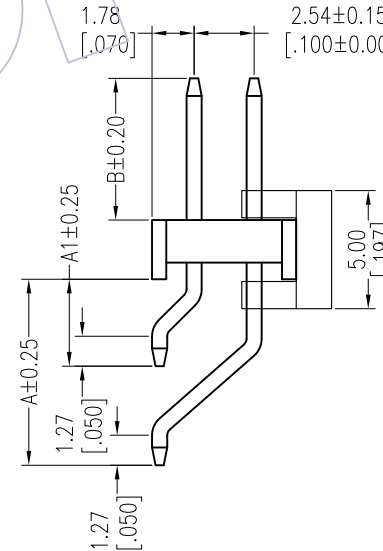
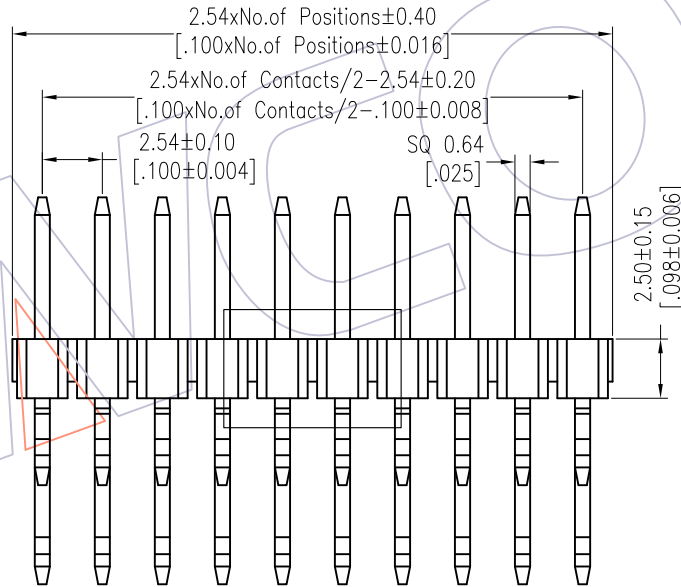

Ordering Information

1125B-12 XX XX Z XXX C R XX $\Delta 2$

No. of Pins Per Row:02~40	Contact Plating G0=Gold Flash G3=10u"Gold G4=15u"Gold G5=30u"Gold S0=Gold Flash/Tin S3=10u"Gold/Tin S4=15u"Gold/Tin S5=30u"Gold/Tin SN=Tin SM=Matte Tin	Pin Length(Short) L=A1+B+3.0 Standard:127=12.7	Insulator Material C=PA9T	Packing A=Tray T=Tube P=Tube+CAP R=Tape&Reel+CAP	Series No. 01~99
------------------------------	---	--	---------------------------------	--	---------------------

Item	Pin Length	A1	A	B	Mating
Standard	12.70	3.68	7.87	6.00	2159
Alternate					

REV	DATE	MODIFICATION DESCRIPTION	CHANGE	OPERATION	DRAW	DATE	SCALE	Fit	PART NO.
A2	2018/01/22	Modify P/N	$\Delta 2$	x.X ±0.40	Ruipeng	2018/01/22	UNIT	mm	1125B-12XXXXZXXCRXX
A1	2014/12/02	Modify	-----	x.XX ±0.25	CHECK	DATE	SIZE	A4	TITLE: PH2.54 DUAL ROW 90°SMT H=2.5 W=6.1
A0	2012/05/15	NEW	-----	x.XXX ±0.15	APPROVE	DATE	SHEET	1/1	Customer NO.
				Angle ± 3'			PROJ.	ϕ	
				DIM TOL					

WCON

Http: www.wcon.com

WCON-Dongguan Tel: +86 769 85358920 Fax: +86 769 85358915 E-mail: sales@wcon.com	WCON-Kunshan Tel: +86 512 57468408 Fax: +86 512 57468468 E-mail: salesks@wcon.com
---	--