

HSF

NOTES:

Rated Current:1.0AMP.
 Contact Resistance:20mΩ Max.
 Withstand Voltage:500V AC/DC
 Insulation Resistance:1000MΩ Min.
 Operation Temperature:-40°C to +105°C

Contact Material:Brass
 Contact Plating:Au or Sn Over Ni
 Insulator Material:PA9T+33%G.F UL94V-0 BK

Ordering Information

1310-11 XX XX M XXX C R XX

No.of Pins	Contact Plating	Pin Length	Insulator	Packing	Series No.
02~50	G0=Gold Flash	L=B+D+1.0+ $\frac{W}{2}$	C=PA9T	A=Tray	01~99
	G3=10u"Gold	Std:052=5.2		T=Tube	
	G4=15u"Gold	063=6.3		P=Tube+CAP	
	G5=30u"Gold	073=7.3		R=Tape&Reel+CAP	
	S0=Gold Flash/Tin				
	S3=10u"Gold/Tin				
	S4=15u"Gold/Tin				
	S5=30u"Gold/Tin				
	SN=Tin				
	SM=Matte Tin				

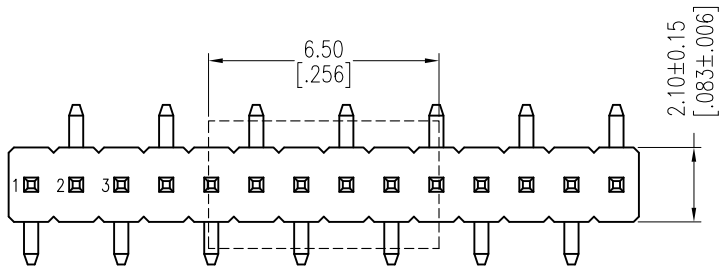

TYPE-1

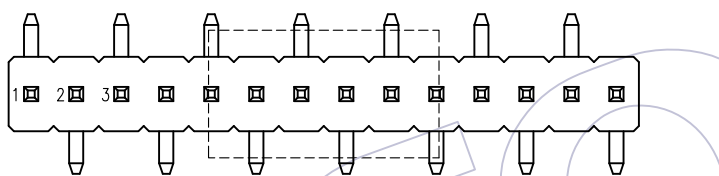

TYPE-2

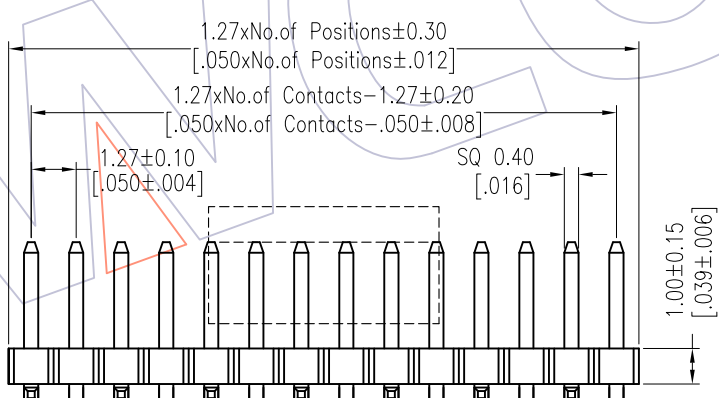

Recommended P.C.B Layout (Top Side) (PCB BOARD TOLERANCE±0.05)

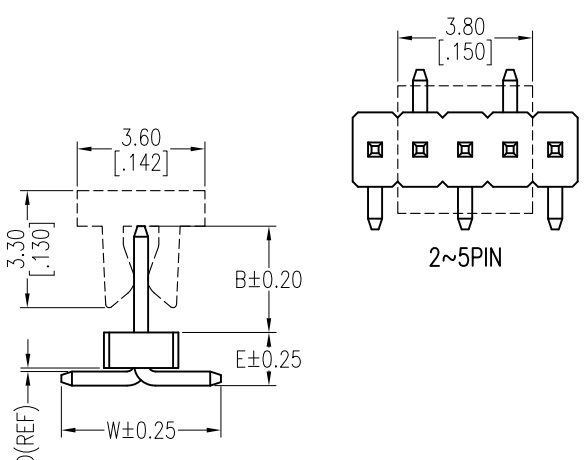
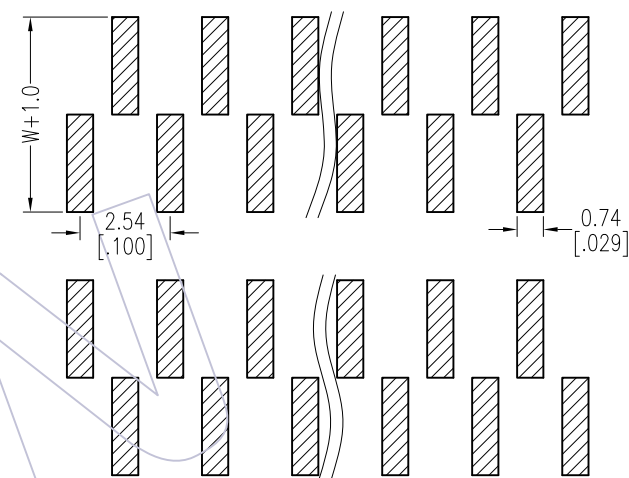

2~5PIN

Item	Pin Length	W	E	B	Mating
Standard	5.2	4.50	1.50	1.90	2321
	6.3	4.50	1.50	3.00	2334
	7.3	4.50	1.50	4.00	2344
Alternate					

REV	DATE	MODIFICATION DESCRIPTION	CHANGE	OPERATION	DRAW	DATE	SCALE	Fit	PART NO.
				x.X ±0.40	William Chen	2018/01/12	UNIT	mm	1310-11XXXXMXXXCXXX
A1	2018/01/12	MODIFY PART NO.	-----	x.XX ±0.25	CHECK	DATE	SIZE	A4	TITLE:
AO	2012/03/12	NEW	-----	x.XXX ±0.15	APPROVE	DATE	SHEET	1/1	1.27 Pin Header, SINGLE ROW, SMT, H=1.0
				Angle ± 3'			PROJ.		Customer NO.
				DIM TOL					



Http: www.wcon.com

WCON-Dongguan Tel: +86 769 85358920 Fax: +86 769 85358915 E-mail: sales@wcon.com	WCON-Kunshan Tel: +86 512 57468408 Fax: +86 512 57468468 E-mail: salesks@wcon.com
---	--