

HSF

NOTES:

Rated Current:3.0AMP.
 Contact Resistance:20mΩ Max.
 Withstand Voltage:500V AC/DC
 Insulation Resistance:1000MΩ Min.
 Operation Temperature:-40°C to +105°C

Contact Material:Brass
 Contact Plating:Au or Sn Over Ni
 Insulator Material:PBT+30%G.F UL94V-0 BK

Recommended P.C.B Layout (Top Side)
 (PCB BOARD TOLERANCE±0.05)
 PCB BOARD Thickness: 1.6–2.0

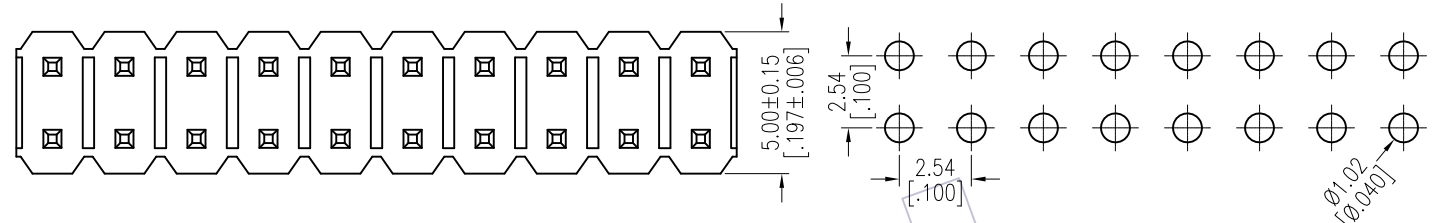

Ordering Information

1001-12 XX XX S XXX A 0 XX ▲

No. of Pins Per Row:02-40	Contact Plating G0=Gold Flash G3=10u"Gold G4=15u"Gold G5=30u"Gold S0=Gold Flash/Tin S3=10u"Gold/Tin S4=15u"Gold/Tin S5=30u"Gold/Tin SN=Tin SM=Matte Tin	Pin Length	Insulator Material A=PBT	Packing 0=PE Bag T=Tube	Series No. 01-99
------------------------------	---	------------	--------------------------------	-------------------------------	---------------------

1001-12XXXXS196X1	12.50	▲
1001-12XXXXS174X1	10.30	
1001-12XXXXS154X1	8.30	
1001-12XXXXS131X1	6.00	▲
1001-12XXXXS129X1	5.80	
1001-12XXXXS098X1	2.70	
PART No.	B	

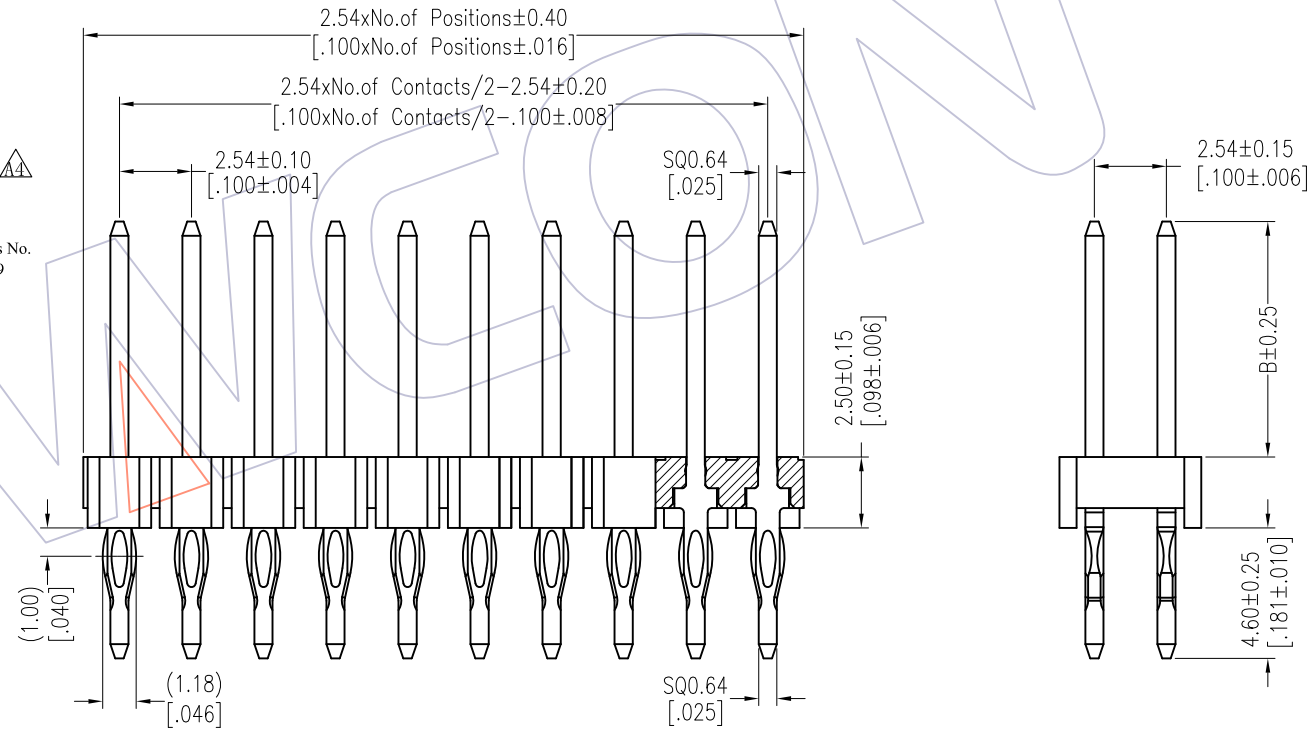

A4	2018/01/22	Modify P/N & Add Pin Length 19.6	▲	OPERATION	DRAW	DATE	SCALE	Fit	PART NO.
A3	2017/09/13	Add Pin Length 13.1	▲	x.X ±0.40	Ruipeng	2018/01/22	UNIT	mm [inch]	1001-12XXXXXXA0XX
A2	2015/04/01	Add Pin Length 9.8	-----	x.XX ±0.25	CHECK	DATE	SIZE	A4	TITLE:
A0	2013/12/31	NEW	-----	x.XXX ±0.15	APPROVE	DATE	SHEET	1/1	2.54 PIN HEADER,DUAL ROW S/T,PRESS FIT
REV	DATE	MODIFICATION DESCRIPTION	CHANGE	Angle ± 3'	DIM	TOL	PROJ.	Customer NO.	

WCON
 Http: www.wcon.com

WCON-Dongguan
 Tel: +86 769 85358920
 Fax: +86 769 85358915
 E-mail: sales@wcon.com

WCON-Kunshan
 Tel: +86 512 57468408
 Fax: +86 512 57468468
 E-mail: salesks@wcon.com