

# HSF

**NOTES:**

Rated Current:3.0AMP.  
 Contact Resistance:20mΩ Max.  
 Withstand Voltage:1000V AC/DC  
 Insulation Resistance:1000MΩ Min.  
 Operation Temperature:-40°C to +105°C

Contact Material:Brass  
 Contact Plating:Au or Sn Over Ni  
 Insulator Material:PA9T+33%G.F UL94V-0 BK

Recommended P.C.B Layout (Top Side)  
 (PCB BOARD TOLERANCE±0.05)

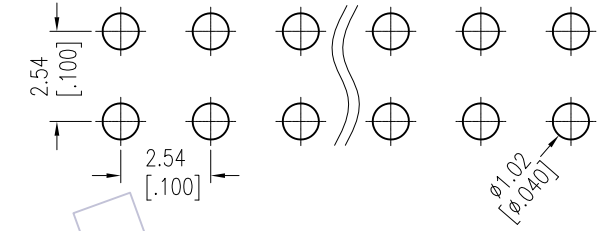
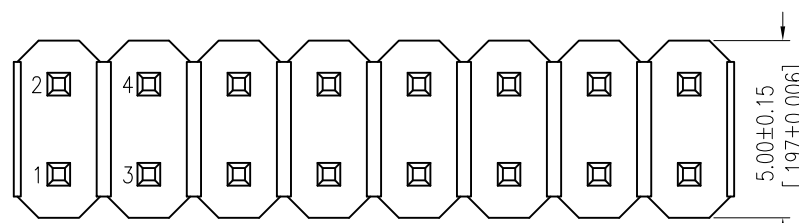

## Ordering Information

1115-12 XX XX S XXX C 0 XX

No.of Pins Per Row:02-40	Contact Plating G0=Gold Flash G3=10u"Gold G4=15u"Gold G5=30u"Gold S0=Gold Flash/Tin S3=10u"Gold/Tin S4=15u"Gold/Tin S5=30u"Gold/Tin SN=Tin SM=Matte Tin	Pin Length L=A+B+1.5 Standard:105=10.5	Insulator Material C=PA9T	Packing 0=PE Bag T=Tube	Series No. 01-99
-----------------------------	---	--	---------------------------------	-------------------------------	---------------------

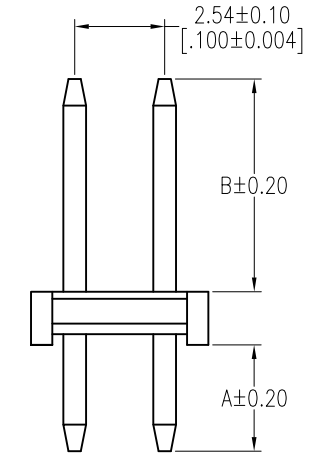
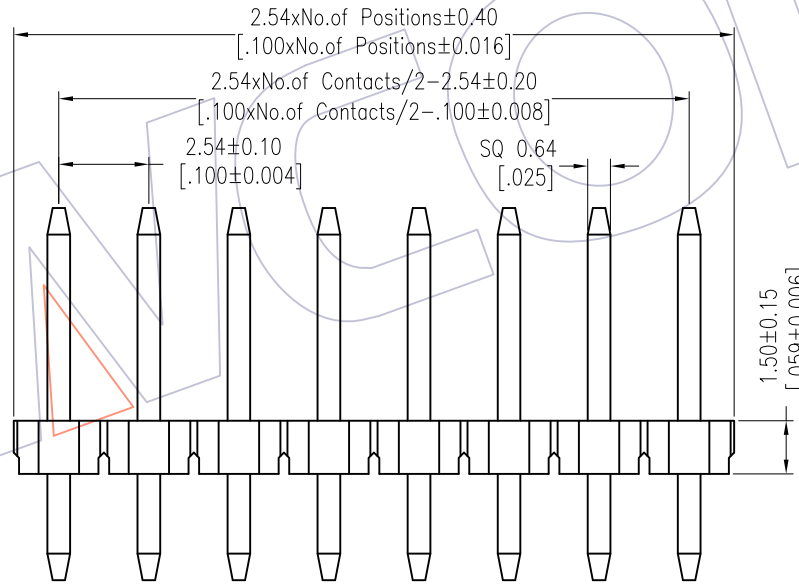

Item	Pin Length	A	B	Mating
Standard	10.50	3.00	6.00	2171 2185
Alternate				

REV	DATE	MODIFICATION DESCRIPTION	CHANGE	OPERATION	DRAW	DATE	SCALE	Fit	PART NO.
				x.x ±0.40	Ruipeng	2018/01/22	UNIT	mm	1115-12XXXXSXXXCOXX
A1	2018/01/22	Modify P/N	△	x.xx ±0.25	CHECK	DATE	SIZE	A4	TITLE:
A0	2012/05/02	NEW	----	x.xxx ±0.15	APPROVE	DATE	SHEET	1/1	PH2.54 DUAL ROW 180° H=1.5
				Angle ± 3'			PROJ.	☉	Customer NO.
				DIM TOL					

# WCON

Http: www.wcon.com

WCON-Dongguan Tel: +86 769 85358920 Fax: +86 769 85358915 E-mail: sales@wcon.com	WCON-Kunshan Tel: +86 512 57468408 Fax: +86 512 57468468 E-mail: salesks@wcon.com
---	--